

VERSION 1

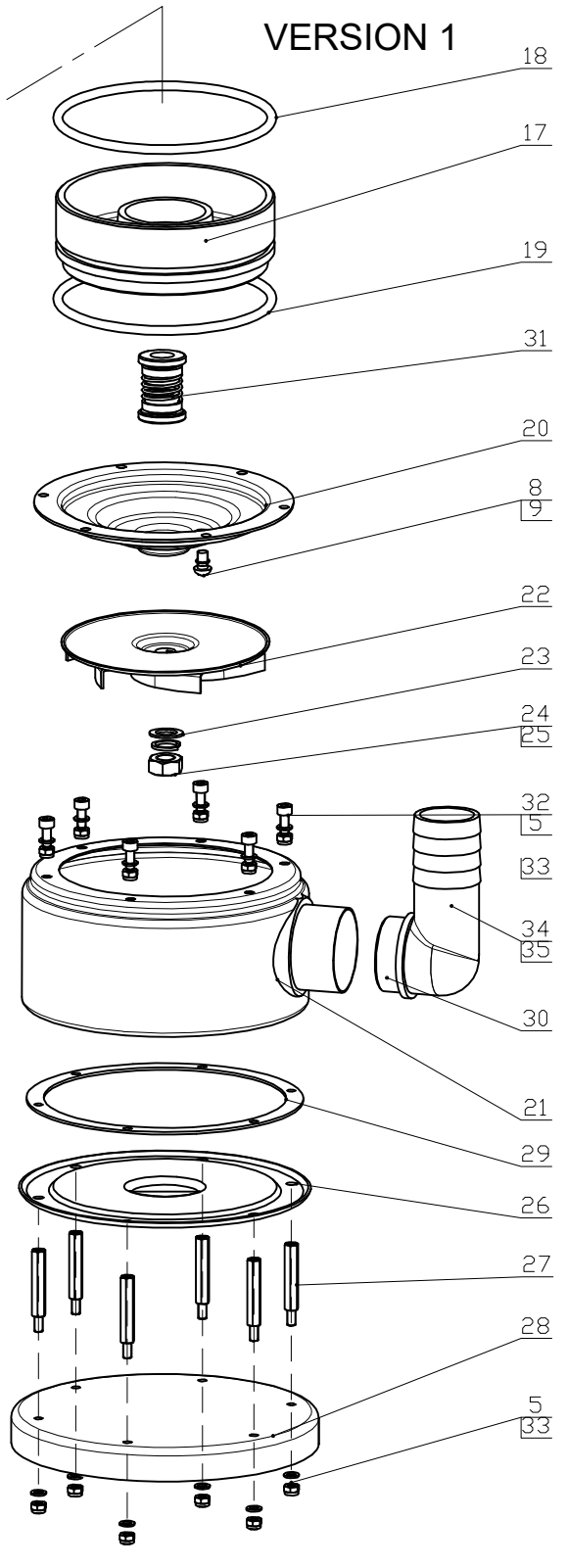

**WQ750M**

# WQ 750M VERSION 1

<b>N.FIGURA</b>	<b>REFERENCIA</b>	<b>DENOMINACION</b>	<b>CANT.</b>
1	Q0050021	CABLE DE ALIMENTACION	1
2	Q005003	ARANDELA PRENSACABLE	2
3	Q005004	TUERCA PRENSACABLE	2
4	Q0911	TORNILLO M5X10	2
5	Q1020	TUERCA M5	14
6	Q003024	ABRAZADERA	2
7	Q003025	GOMA	2
8	Q005027	TORNILLO M6X16	2
9	Q0602	JUNTA TORICA 6 X1,9	2
10	Q0050052	TAPA BOMBA	1
11	Q005006	SOPORTE SUPERIOR	1
12	Q0512	TERMICO 17AM032	1
13	Q1113	ARANDELA COMPENSACION	1
14-15	Q007002+STATOR	STATOR + CUERPO MOTOR 750W 230V MONO	1
16	Q012003	ROTOR	1
17	Q005012	SOPORTE INFERIOR	1
18	Q0614	JUNTA TORICA 120X3,1	1
19	Q0615	JUNTA TORICA 120X5,3	1
20	Q005013	CAMARA DE ACEITE	1
21	Q005037	CUERPO BOMBA	1
22	Q012004	RODETE	1
23	Q011005	ARANDELA	2
24	Q1007	TUERCA M10	1
25	Q1109	ARANDELA D10	1
26	Q011006	BASE	1
27	Q035003	TUERCA	6
28	Q035002	BASE	1
29	Q005017	JUNTA	1
30	Q0606	JUNTA TORICA 38X2	1
31	Q0434	SELLO MECANICO	1
32	Q0905	TORNILLO M5X10	12
33	Q1102	ARANDELA D5	12
34	Q11240	CODO DE DESCARGA Ø 40	1
34	Q11250	CODO DE DESCARGA Ø 50	1
35	Q005036	TUERCA	1
36	Q0104	RODAMIENTO 6204	1
37	Q0103	RODAMIENTO 6202	1
38	Q09081	TORNILLO M4X8	1
39	Q1136	ARANDELA	1
40	---	GROUNDING SYMBOL	1
41	Q0316	CONDENSADOR 25 MF	1
42	Q005024	JUNTA	1
43	Q0613	JUNTA TORICA 115X3,1	1
44	Q005026	ASA	1
45	Q005039	FLOTADOR	1

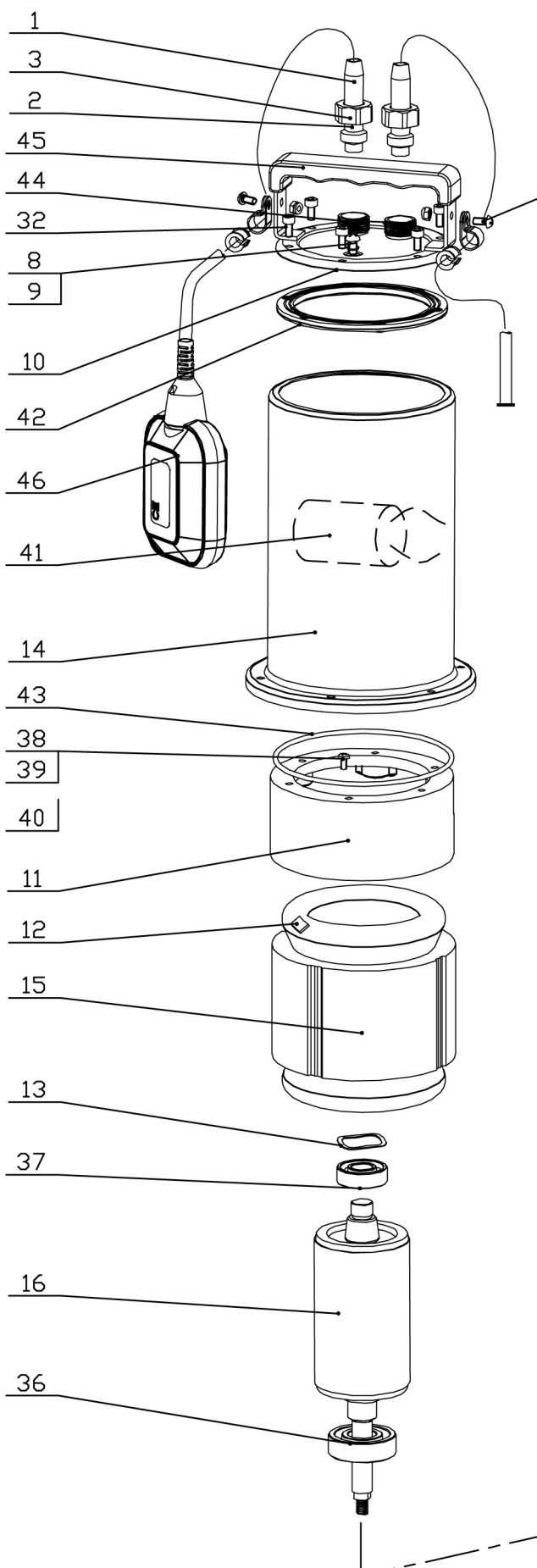

VERSION 2

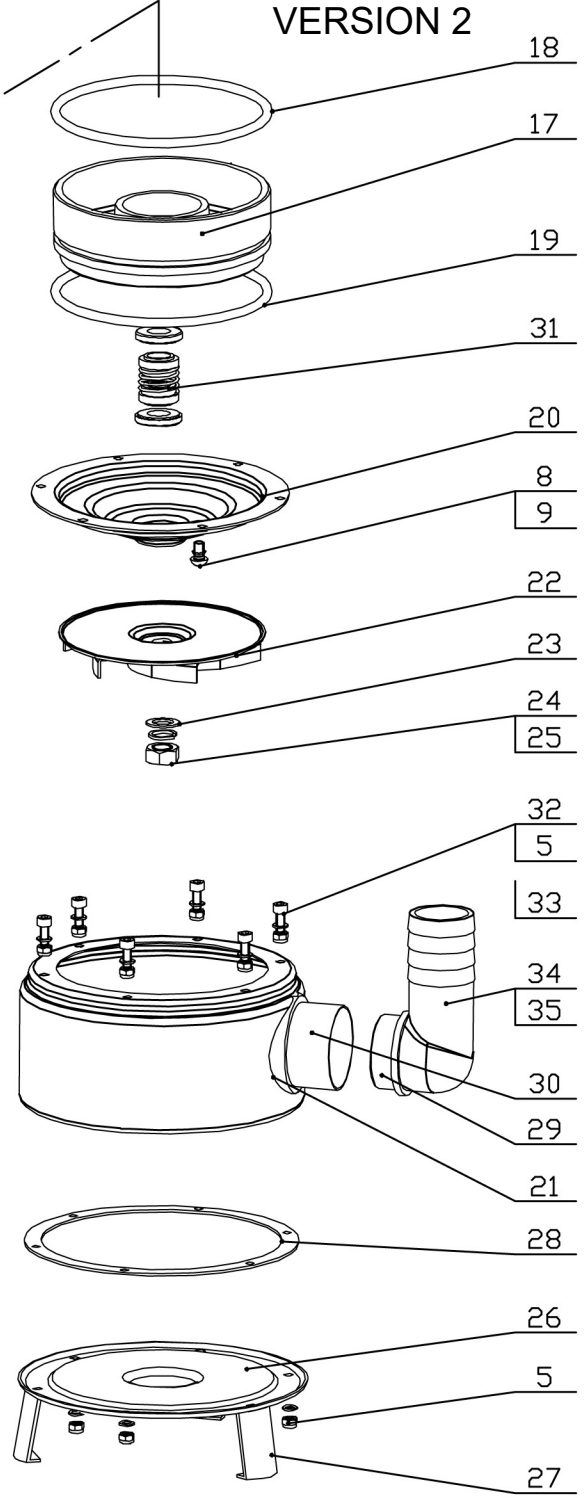

**WQ-750M**

# WQ 750M VERSION 2

<b>N.FIGURA</b>	<b>REFERENCIA</b>	<b>DENOMINACION</b>	<b>CANT.</b>
1	Q0050021	CABLE DE ALIMENTACION	1
2	Q005003	ARANDELA PRENSACABLE	2
3	Q005004	TUERCA PRENSACABLE	2
4	Q0911	TORNILLO M5X10	2
5	Q1020	TUERCA M5	14
6	Q003024	ABRAZADERA	2
7	Q003025	GOMA	2
8	Q005027	TORNILLO M6X16	2
9	Q0602	JUNTA TORICA 6 X1,9	2
10	Q0050052	TAPA BOMBA	1
11	Q005006	SOPORTE SUPERIOR	1
12	Q0512	TERMICO 17AM032	1
13	Q1113	ARANDELA COMPENSACION	1
14-15	Q007002+STATOR	STATOR + CUERPO MOTOR 750W 230V MONO	1
16	Q012002	ROTOR	1
17	Q005012	SOPORTE INFERIOR	1
18	Q0614	JUNTA TORICA 120X3,1	1
19	Q0615	JUNTA TORICA 120X5,3	1
20	Q005013	CAMARA DE ACEITE	1
21	Q005037	CUERPO BOMBA	1
22	Q012004	RODETE	1
23	Q011005	ARANDELA	2
24	Q1007	TUERCA M10	1
25	Q1109	ARANDELA D10	1
26	Q011006	BASE	1
27	Q011007	PIE	3
28	Q005017	JUNTA	1
29	Q0606	JUNTA TORICA 38X2	1
30	Q005020	TUBO DE DESCARGA	1
31	Q0434	SELLO MECANICO	1
32	Q0905	TORNILLO M5X10	12
33	Q1102	ARANDELA D5	12
34	Q11240	CODO DE DESCARGA Ø 40	1
34	Q11250	CODO DE DESCARGA Ø 50	1
35	Q005036	TUERCA	1
36	Q0104	RODAMIENTO 6204	1
37	Q0103	RODAMIENTO 6202	1
38	Q09081	TORNILLO M4X8	1
39	Q1136	ARANDELA	1
40	---	GROUNDING SYMBOL	1
41	Q0316	CONDENSADOR 25 MF	1
42	Q005024	JUNTA	1
43	Q0613	JUNTA TORICA 115X3,1	1
44	Q005025	CONECTOR	2
45	Q005026	ASA	1
46	Q005039	FLOTADOR	1