

NEW

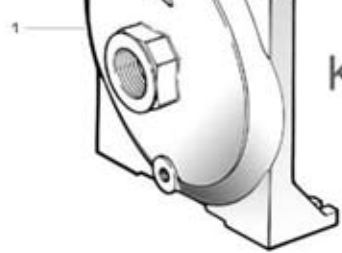

KM400-550

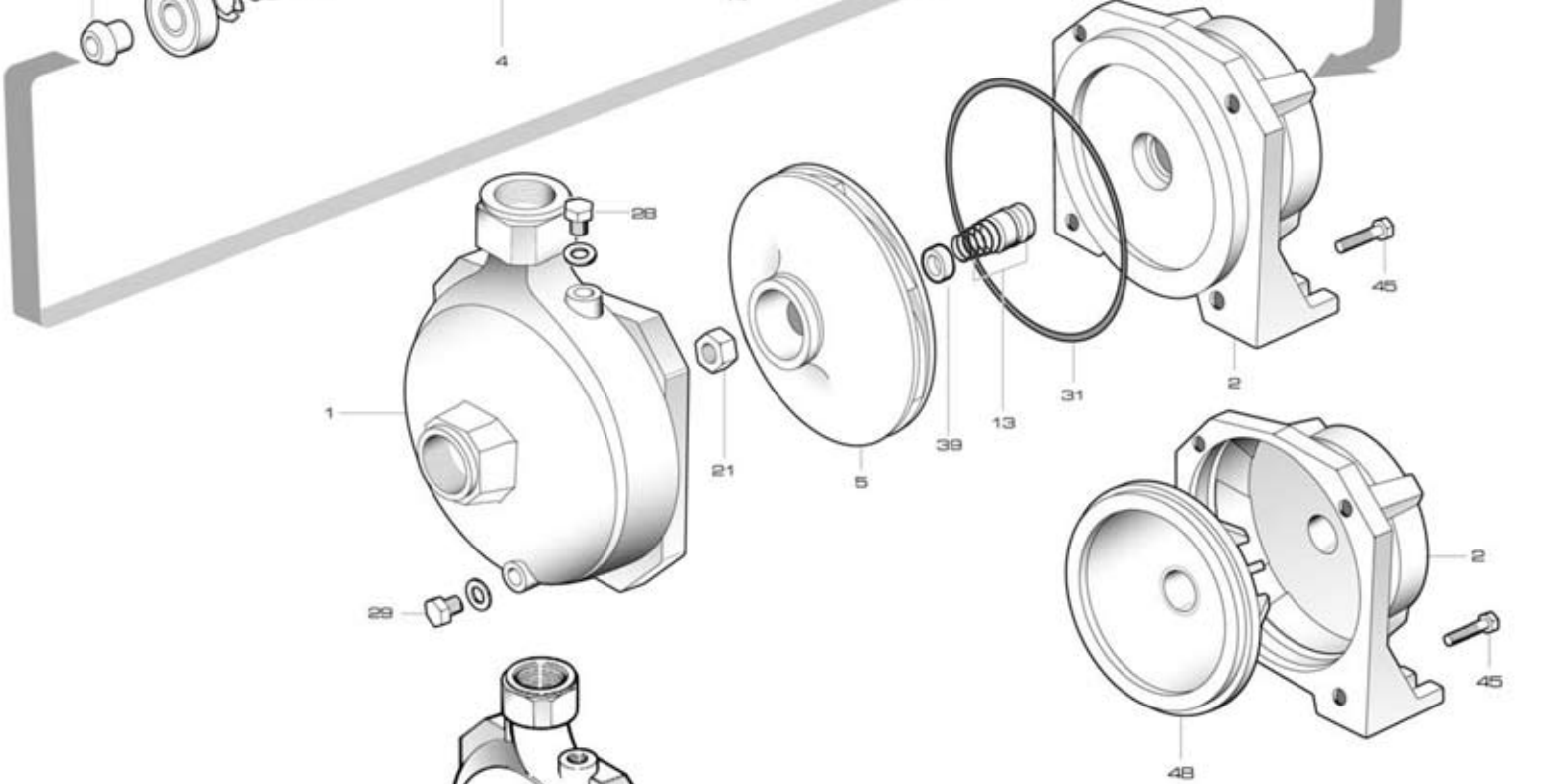
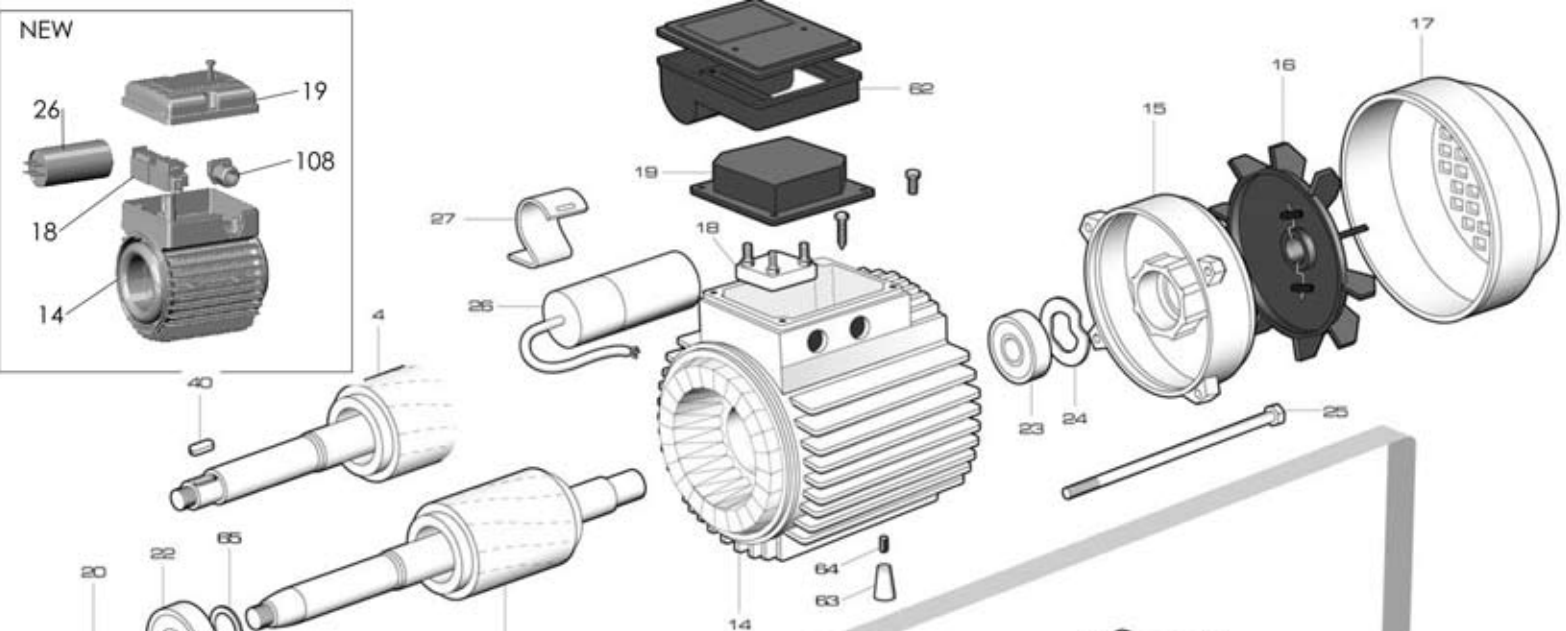
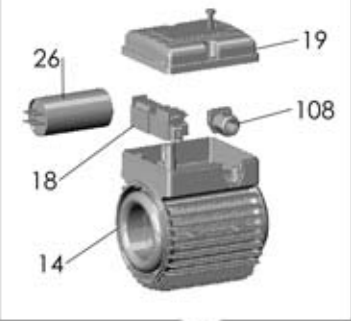
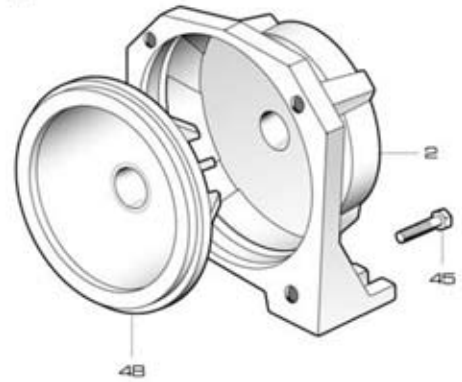

KM 75-100  
supporto alluminio  
aluminium motor bracket

# KM 214

RIF	DESCRIZIONE	CODICE
1	corpo pompa	S70017012A
2	supporto pompa motore ghisa	S70046067
4	albero con rotore monofase	S75405010C
5	girante ottone	S71127008C
5	girante Noryl®	M72527008C
13	tenuta meccanica	M60400010/1
14	cassa con statore monofase	S57900325A
15	coperchio motore	S70214004
16	ventola	M60100003
17	copriventola	M60200027
18	morsettiera monofase	M61100008
20	paraspruzzi	M72606000
21	dado bloccaggio girante	M60513004
22	cuscinetto lato pompa	M60300020
23	cuscinetto lato ventola	M60300002
24	anello di compensazione	M60603002
25	tirante motore	M75450003
26	condensatore 50 µF - 450 V	M61400024
28	tappo di riempimento	M75147001
29	tappo di scarico	M75147001
31	anello O-R corpo pompa	M60900011
40	linguetta	M61000001
45	vite corpo-supporto ghisa	M60500069
62	scatola portacondensatore	M62700019F
63	pedino d'appoggio	M75403022
64	vite pedino	M60505028
65	anello darresto	M60602001