

NEW

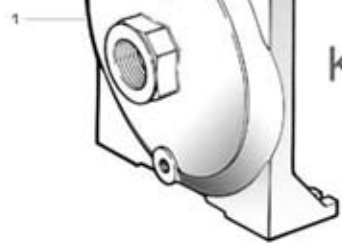

KM400-550

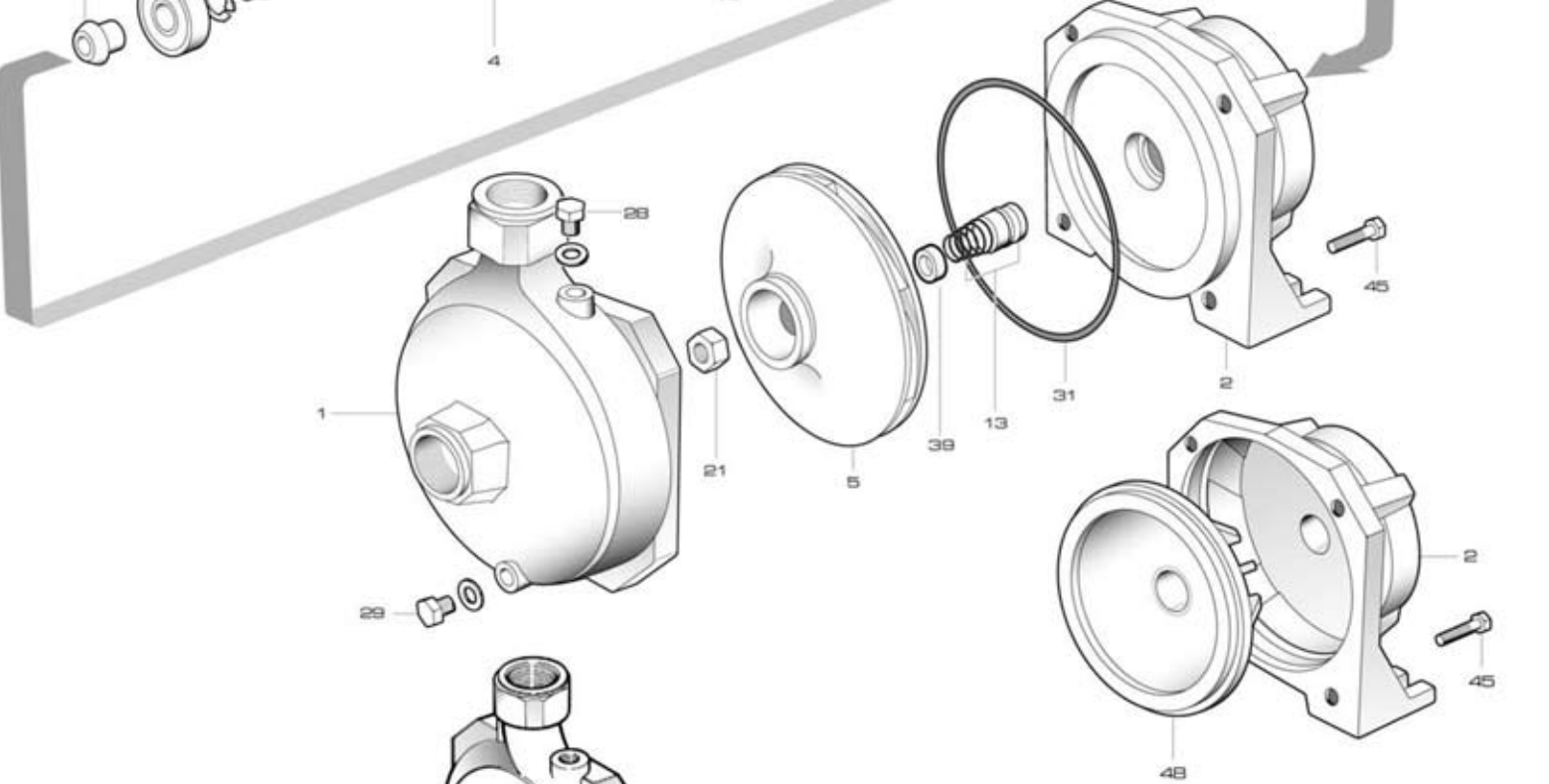
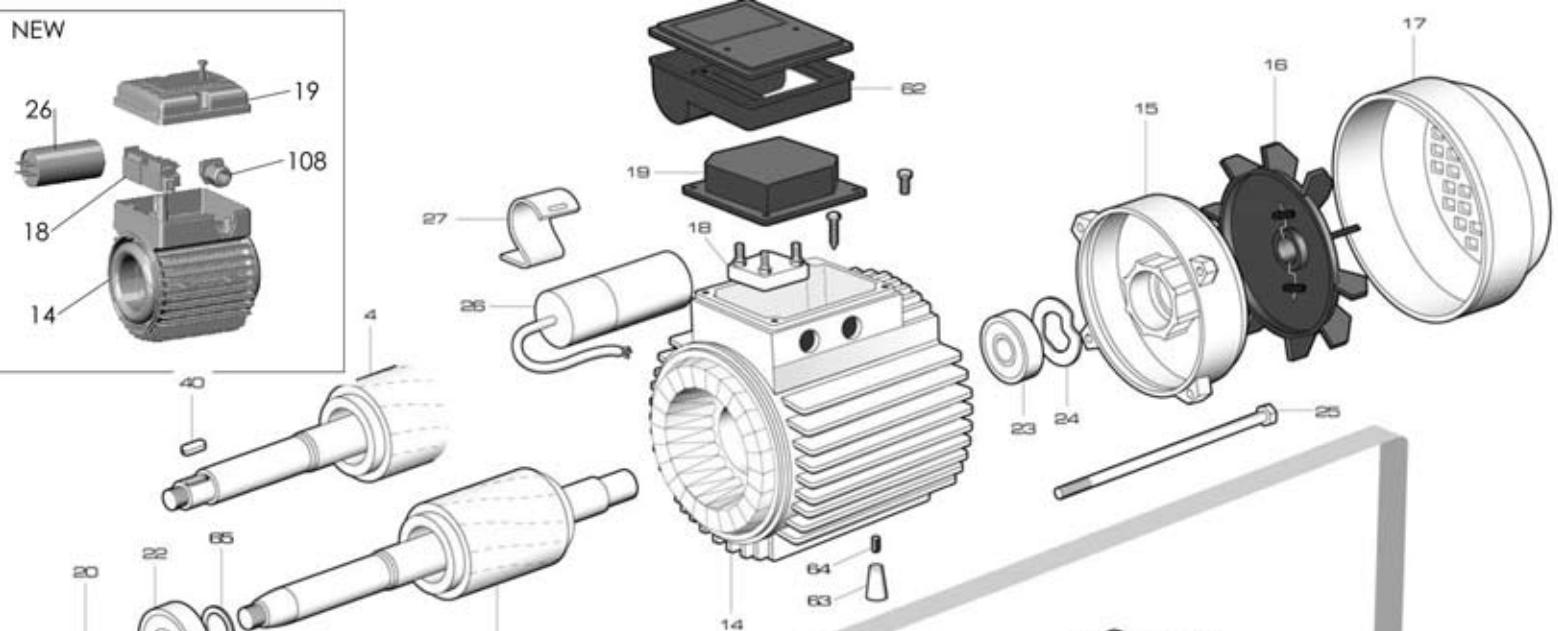
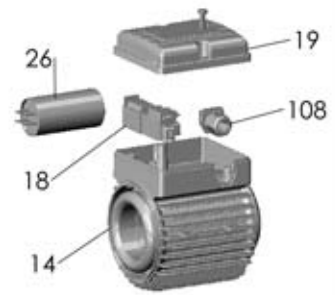
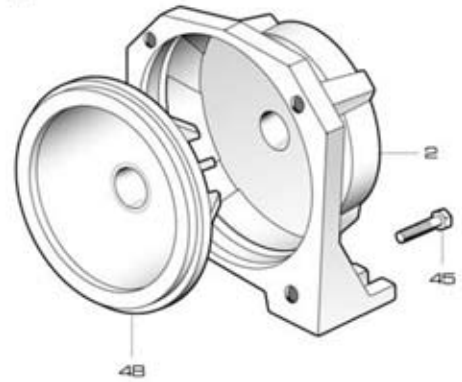

KM 75-100  
supporto alluminio  
aluminium motor bracket

# KM 210 T

RIF	DESCRIZIONE	CODICE
1	corpo pompa	S70017012
2	supporto pompa motore ghisa	S70046067
4	albero con rotore trifase	S75405010A
5	girante ottone	S71127008A
5	girante Noryl®	M72527008A
13	tenuta meccanica	M60400010/1
14	cassa con statore trifase	S57900016
15	coperchio motore	S70214004
16	ventola	M60100003
17	copriventola	M60200027
18	morsettiera trifase	M61100003
19	coprimorsettiera	M62700001
20	paraspruzzi	M72606000
21	dado bloccaggio girante	M60513004
22	cuscinetto lato pompa	M60300020
23	cuscinetto lato ventola	M60300002
24	anello di compensazione	M60603002
25	tirante motore	M75450003
28	tappo di riempimento	M75147001
29	tappo di scarico	M75147001
31	anello O-R corpo pompa	M60900011
40	linguetta	M61000001
45	vite corpo-supporto ghisa	M60500069
63	pedino d'appoggio	M75403022
64	vite pedino	M60505028
65	anello darresto	M60602001