

HGAM

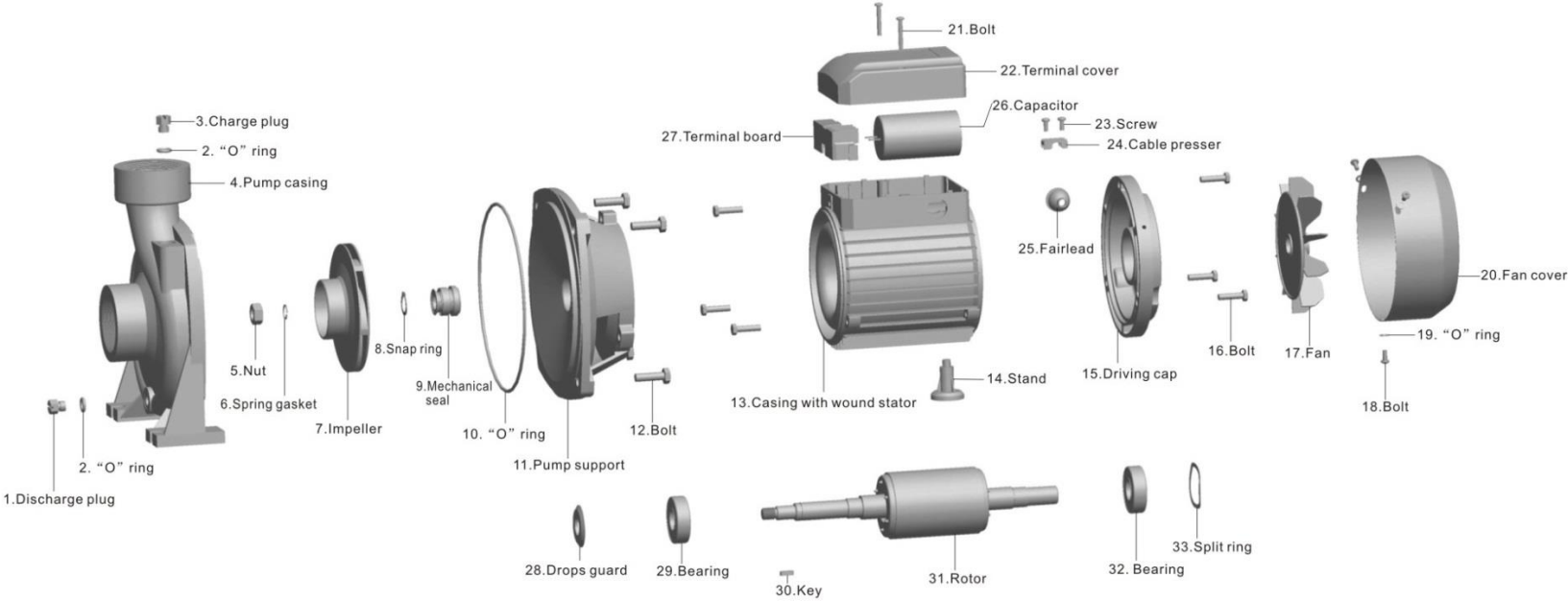

HGAM-75

N.FIGURA	CODIGO	DENOMINACION
1	XJWM/3BH-1	TAPON DE DESAGÜE
2	CPM-02158	JUNTA TORICA
3	CPM-15819	TAPON DE LLENADO
4	HGAM70-04	CUERPO BOMBA
5	XJWM/3BH-11	TUERCA
6A	XJM100L-50	ARANDELA MUELLE
6B	XJM100L-51	ARANDELA
7	HGAM75-07	RODETE
8	XCM158-6	ARANDELA DE AJUSTE
9	HGAM75-09	SELLO MECANICO
10	HGAM70-10	JUNTA TORICA
11	HGAM75-11	SOPORTE BOMBA
12	HGAM75-12	TORNILLO
13	HGAM75-13	CONJUNTO STATOR
14	HGAM75-14	PIE DE APOYO
15	HGAM75-15	TAPA TRASERA MOTOR
16	HGAM75-16	TORNILLO
17	HGAM75-17	VENTILADOR
18	HGAM70-18	TORNILLO
19	HGAM70-19	JUNTA TORICA
20	HGAM75-20	TAPA VENTILADOR
21	XCM158-30	TORNILLO
22	XCM158-29	TAPA CUADRO
23	XJM100L-61	TORNILLO
24	XJM100L-38	PRENSACABLE
25	XCM158-34	GOMA PRENSACABLES
26	XCM158-31	CONDENSADOR
27	XCM158-28	REGLETA
28	3XCM100S-3	PROTECTOR
29	CPM-28180	RODAMIENTO
30	HGAM75-30	CHAVETA
31	HGAM75-31	ROTOR
32	CPM-31180	RODAMIENTO
33	CPM-32180	ARANDELA DE COMPENSACION