

PB-55022

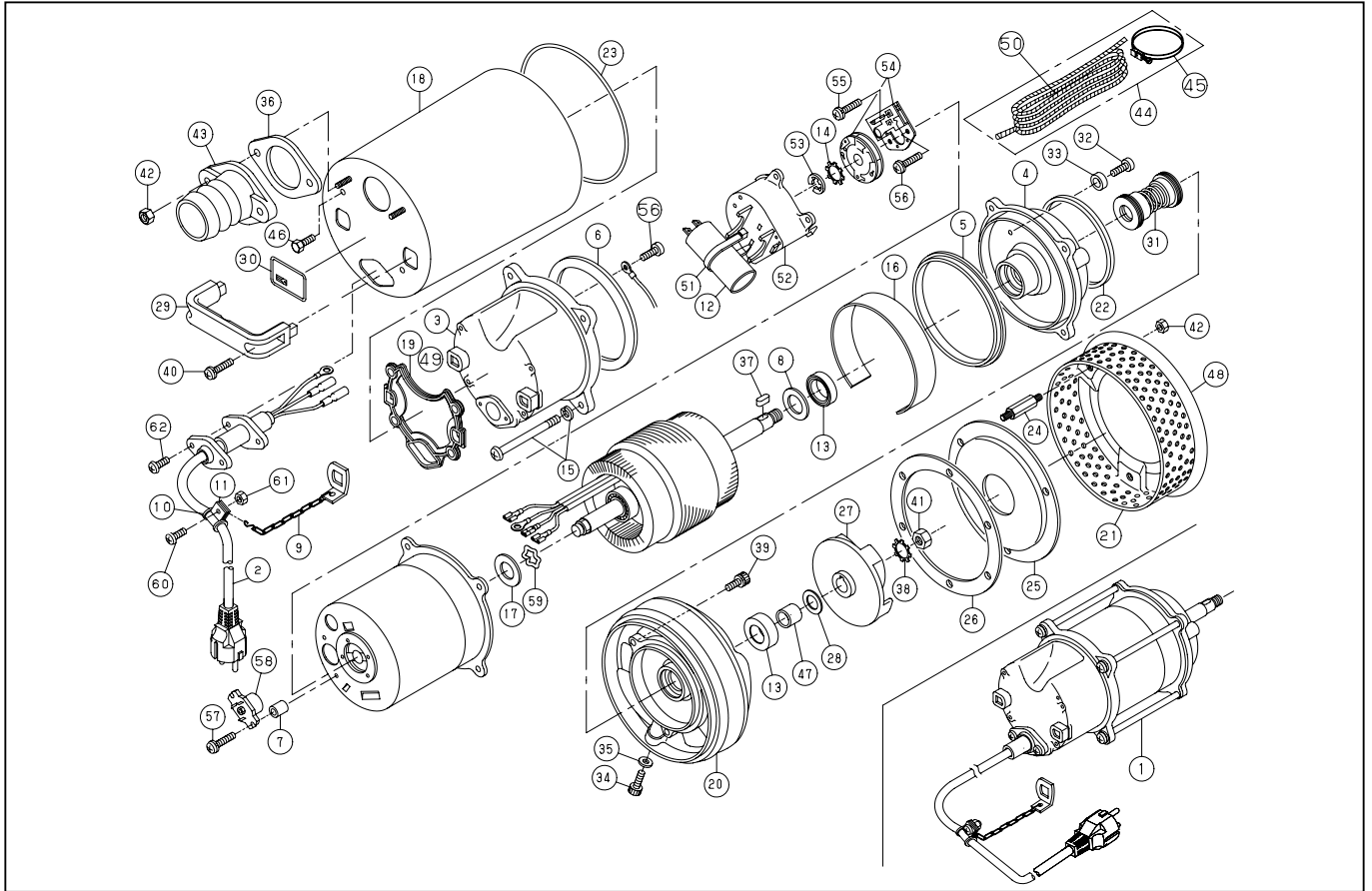

DWG No.043854009 MODEL:PB-55022 FORM:PB-55022-BAD-2

No.	PARTS CODE	PARTS NAME	QTY	MATERIAL	SIZE	REMARKS
1	043803004	MOTOR ASSY	1			KSP-4002D
2	043805801	POWER CORD ASSY	1	HO7RN-F	10M	
3	043001206	HEAD COVER	1	ADC		
4	043000907	FRONT BRACKET	1	ADC		
5	043000402	FRAME PACKING	1	NBR		
6	043000302	HEAD PACKING	1	NBR		
7	043000203	SPACER	2	AL		
8	039002601	BEARING WASHER	1	SPC		
9	039812301	CHAIN ASSY	1			
10	039003101	CORD SUPPORTER	1	CR		
11	026001801	CORD BAND	1	SUS		
12	039000201	100V-400W CONDENSER	1			125VAC150 μ F
13	893555043	OIL SEAL	2	NBR	SC14.28.7	
14	039014101	TOOTHED WASHER	1		φ 10	
15	043004301	+ SCREW	4	SUS	M6X 145	
16	043002302	SUPPORTER	1	SPG		
17	043008201	WAVE HOLDER	1	SPG		
18	043000804	OUT COVER	1	SPHC		
19	043001302	OUTER PACKING	1	NBR		
20	043013601	CASING	1	ADC		
21	043000703	STRAINER	1	SPCC		
22	889955100	O-RING	1	NBR	G100	
23	043002501	O-RING	1	NBR	φ 166	
24	043001403	STUD BOLT	3	SWRM		
25	039001601	SUCTION COVER	1	SPHC		
26	039001902	SUCTION PACKING	1		T0.6	
27	039003404	IMPELLER	1	FC	50HZ	
28	039002501	IMPELLER ADJUSTING WASHER	2	SUS		
29	043007802	HANDLE	1	PC		
30	043013803	LABEL	1			

PB-55022

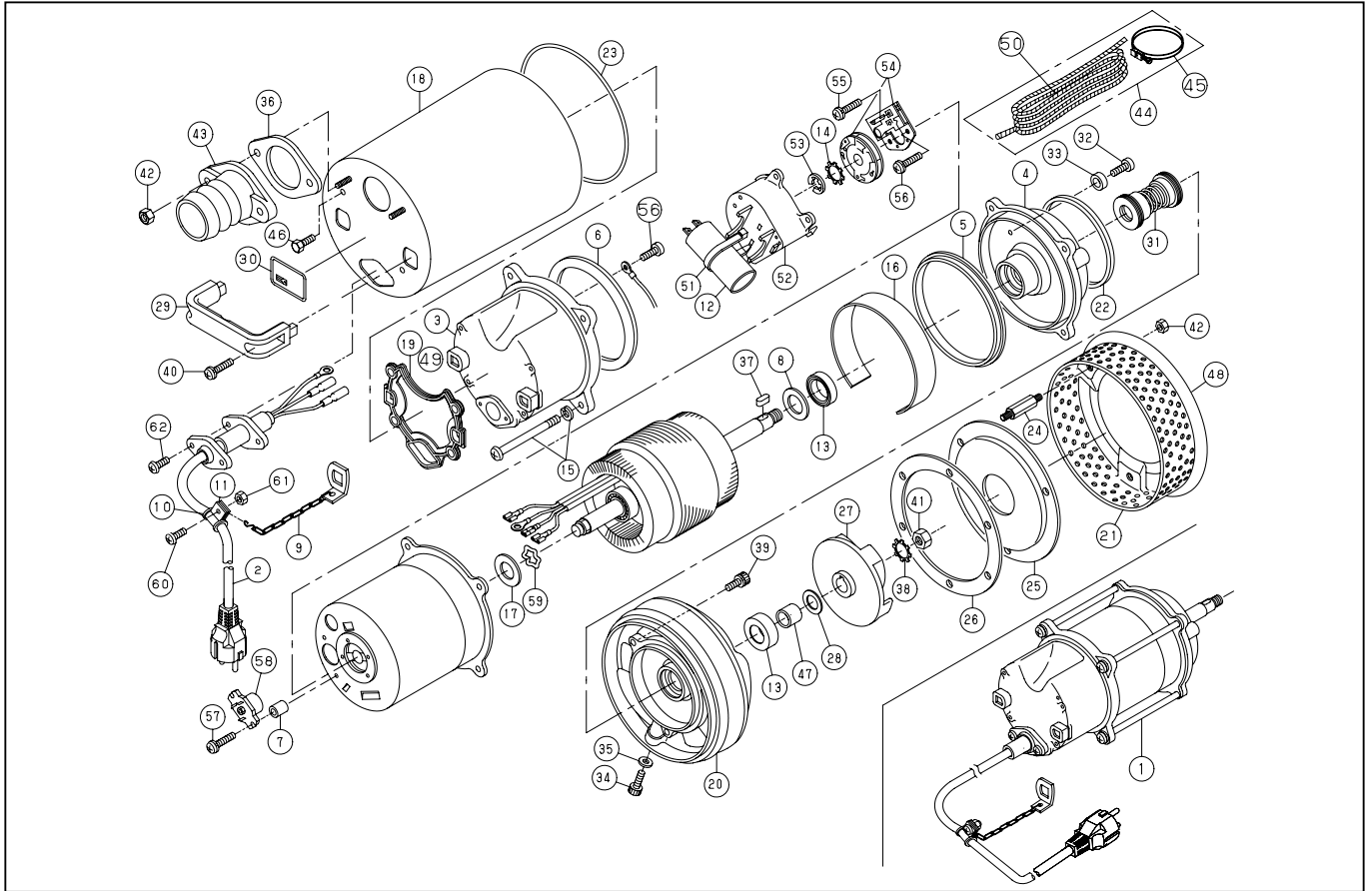

DWG No.043854009 MODEL:PB-55022 FORM:PB-55022-BAD-2

No.	PARTS CODE	PARTS NAME	QTY	MATERIAL	SIZE	REMARKS
31	039000301	MECHANICAL SEAL	1	DE560		
32	034015301	+ SCREW	1	SUS	M6X8	
33	034014202	SEAL RING	1	NBR		
34	039003702	HEXAGON SOCKET BOLT	1	SUS	M10X12	
35	854255010	SEAL WASHER	1		φ 10	
36	039009201	DELIVERY PACKING	1	CR		
37	884205023	KEY	1		4X4X10	
38	845205010	TOOTHED WASHER	1	SUS	10A	
39	043004401	HEXAGON SOCKET BOLT	3	SUS	M6X20	
40	707605057	+ SCREW	2	SUS	M6X20	
41	827405010	HEXAGON NUT	1	SUS	M10	
42	827405008	HEXAGON NUT	5	SUS	M8	
43	039007701	DELIVERY FLANGE	1	ADC		
44	043804901	ACCESSORIES SET	1			
45	940019060	HOSE BAND	1		φ 60	
46	747805028	HEXAGON BOLT	4	SUS	M6X12	
47	043007401	PB-50 SLEEVE	1	SUS		
48	043007502	BOTTOM PLATE	1	SPHC		
49	043009601	OUT PACKING	1	CR		
50	039010101	ROPE	1		5M	
51	039014201	BAND	1	CV-150		
52	043002203	CENTRIFUGAL FORCE SWITCH COVER	1	PBT		
53	888727008	STOP RING	1	SK		
54	039000101	CENTRIFUGAL FORCE SWICH	1			
55	707825018	+ SCREW	2		M3X6	
56	707819036	+ SCREW	3	SWRM	M4X8	
57	708119037	+ SCREW	2	SWRM	M4X10	
58	039032601	THERMAL PROTECTER	1			
59	857627023	WAVE WASHER	1		WW-23	
60	703305100	+ SCREW	1	SUS	M5X10	

PB-55022

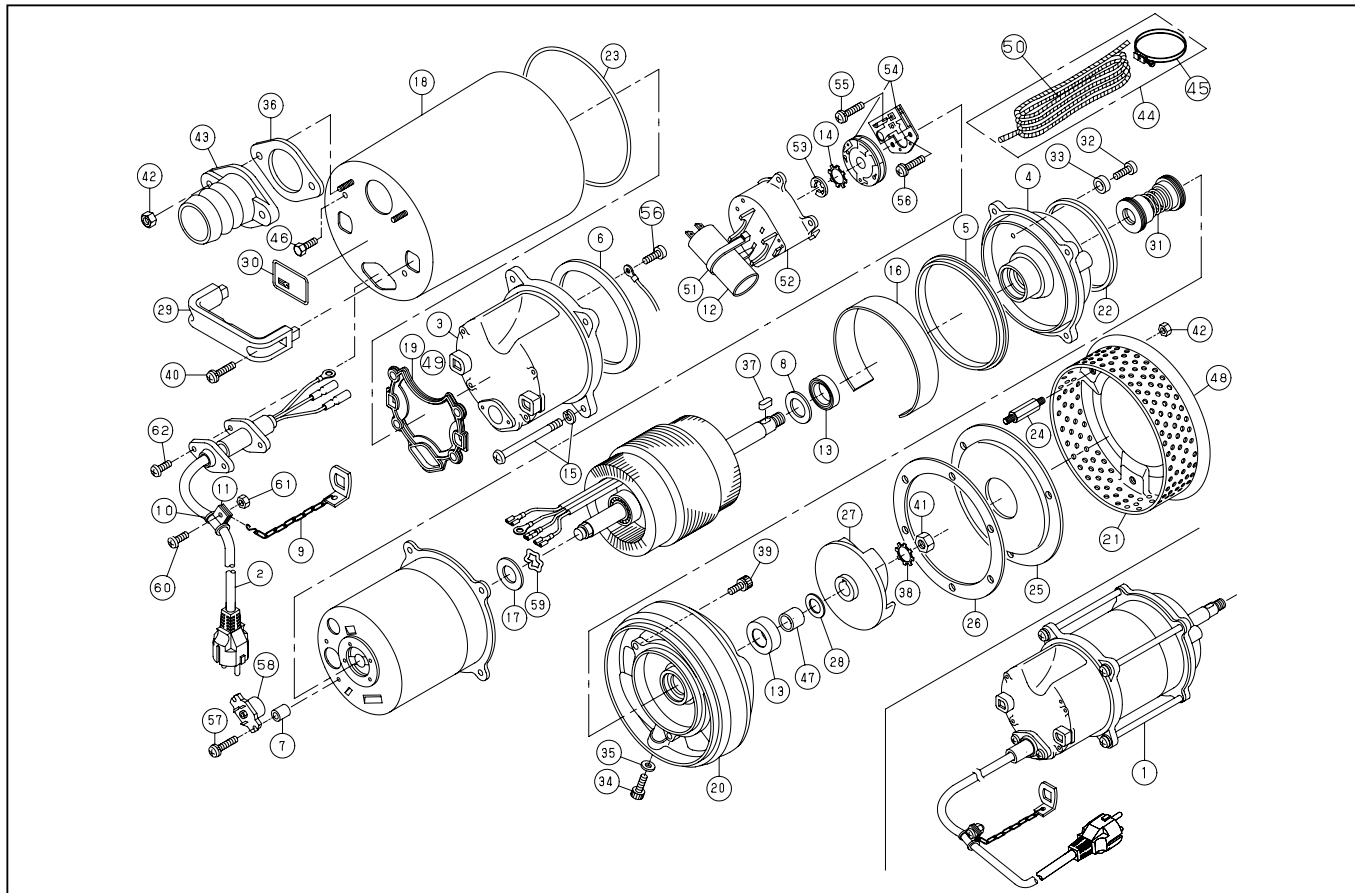

DWG No.043854009 MODEL:PB-55022 FORM:PB-55022-BAD-2

No.	PARTS CODE	PARTS NAME	QTY	MATERIAL	SIZE	REMARKS
61	827305005	HEXAGON NUT	1	SUS	M5	
62	703305102	+ SCREW	2	SUS	M5X14	
	039013901	PARAFFIN OIL		170cc		@160/100cc
	043004503	OPERATION MANUAL				
	043013905	PACKING CASE				
	043021101	DECLARATION OF CONFORMITY				