

NEW

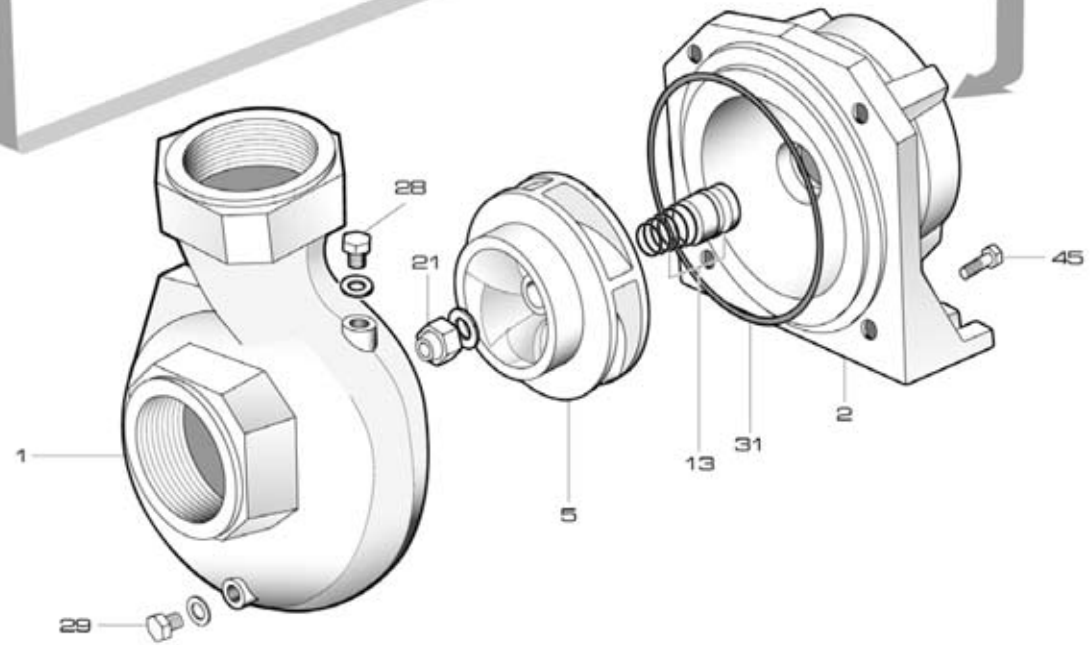
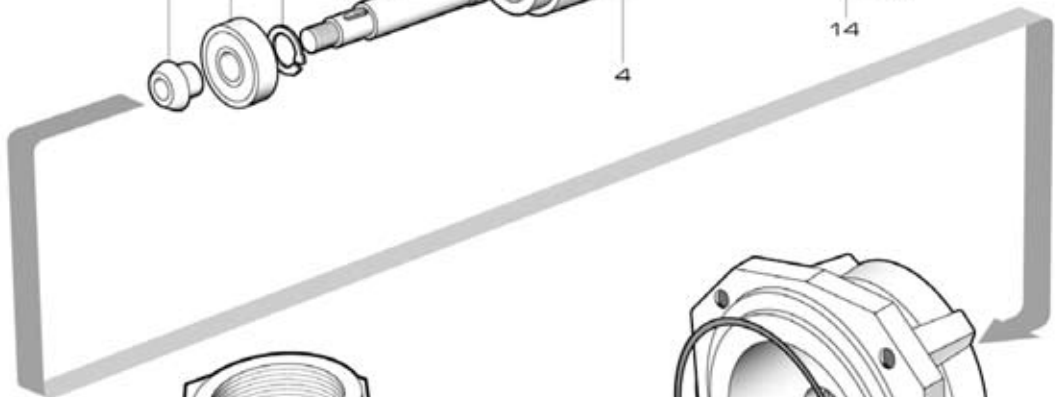
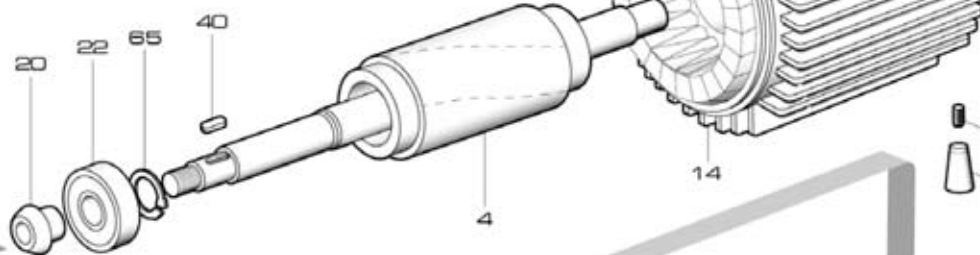
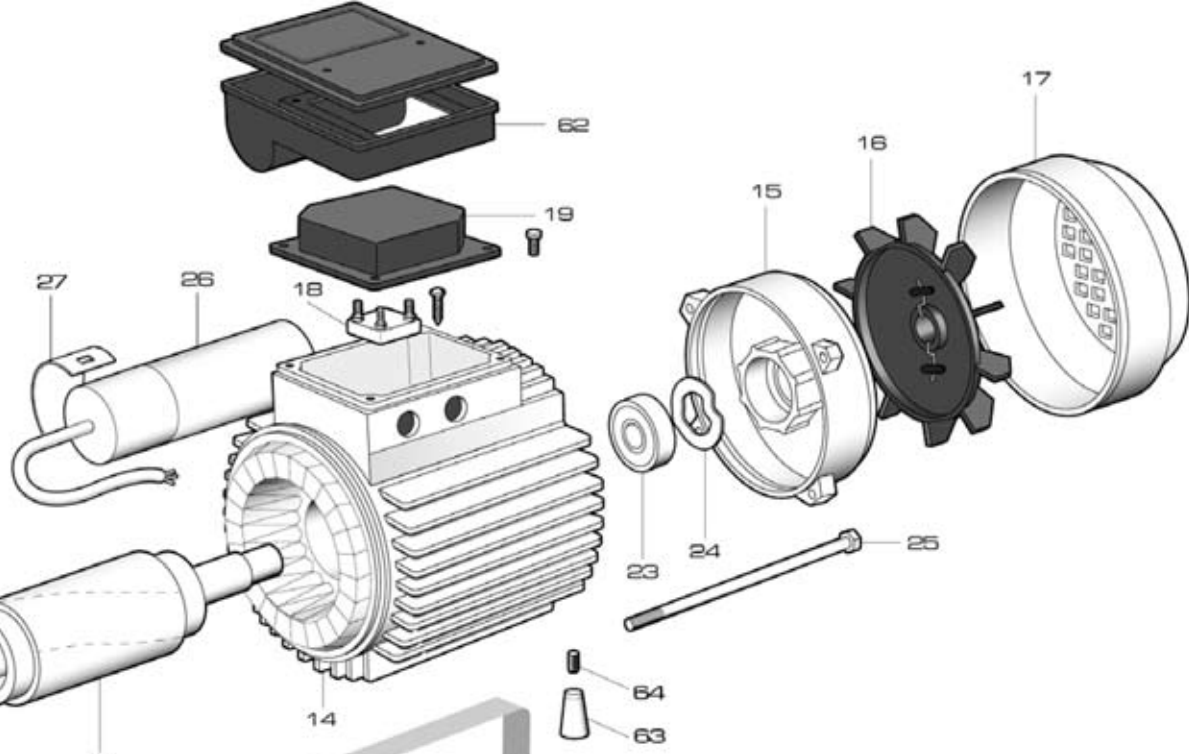
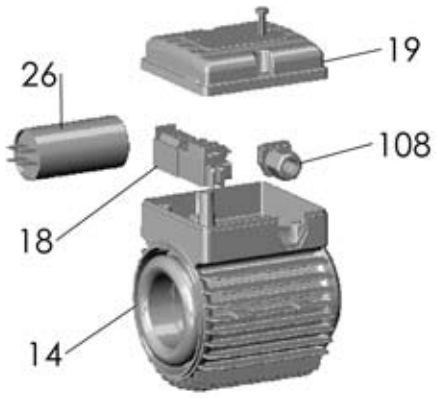

# SD 80/2

RIF	DESCRIZIONE	CODICE
1	corpo pompa	S70017014
2	supporto pompa motore	S70046005
4	albero con rotore monofase	S75405012
4	albero con rotore trifase	S75405012B
5	girante ghisa	S70027011A
13	tenuta meccanica	M60400008/9
14	cassa con statore monofase	S57900007
14	cassa con statore trifase	S57900006
15	coperchio motore	S70214001
16	ventola	M60100002
17	copriventola	M60200026
18	morsettiera trifase	M61100001
18	morsettiera monofase	M61100007
19	coprimorsettiera	M62700000
20	paraspruzzi	M72606003
21	dado bloccaggio girante	M60513004
22	cuscinetto lato pompa	M60300001
23	cuscinetto lato ventola	M60300001
24	anello di compensazione	M60603001
25	tirante motore	M75450002
26	condensatore 14 $\mu$ F - 450 V	M61400003
28	tappo di riempimento	M75147001
29	tappo di scarico	M75147001
31	anello O-R corpo pompa	M60900007
40	linguetta	M61000000
45	vite corpo-supporto	M60500042
62	scatola portacondensatore	M62700015
63	pedino	M72503011
64	vite pedino	M60505027