

NEW

PLUS SV

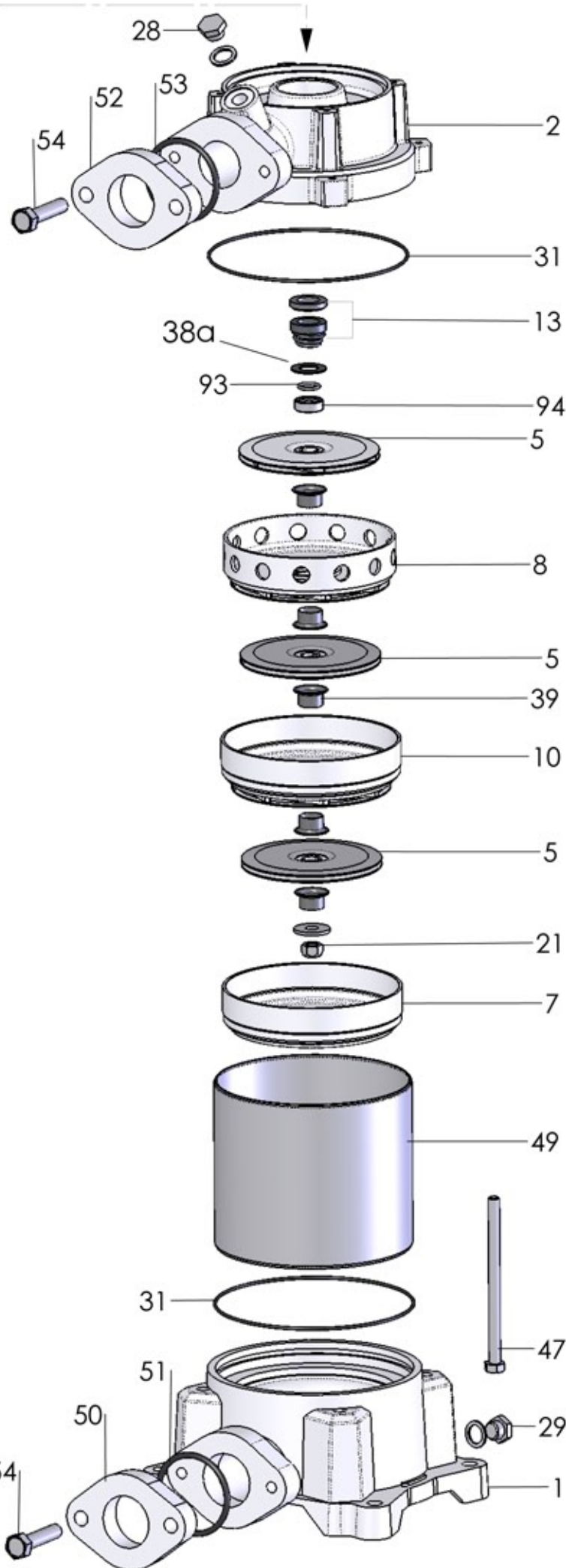
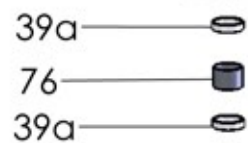
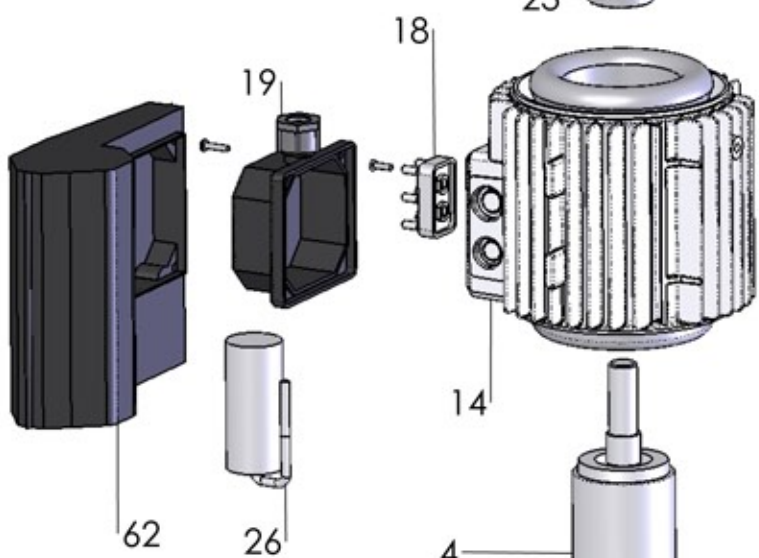
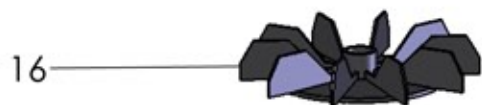
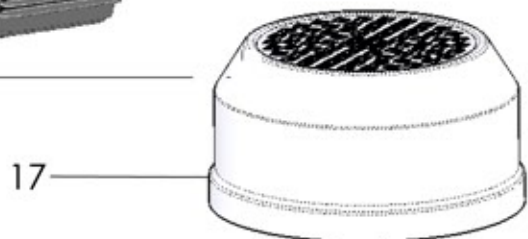
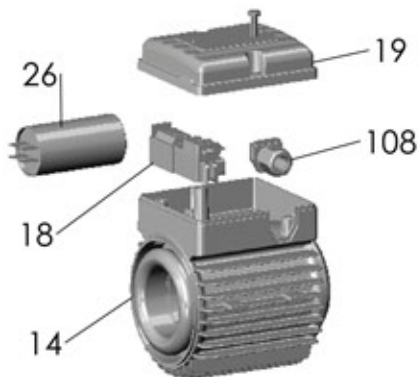

P 5SV 350/11

RIF	DESCRIZIONE	CODICE
1	corpo pompa	S70017056
2	supporto pompa motore	S70046048
4	albero con rotore monofase	S75405151S
4	albero con rotore trifase	S75405151A
5	girante in acciaio	M31427152
7	diffusore aspirante	M31419031
8	diffusore premente	M31419032
10	diffusore	M31419030
10a	diffusore con boccola	M72519033
13	tenuta meccanica	M60400047/8
14	cassa con statore monofase	S57900234
14	cassa con statore trifase	S57900233
15	coperchio motore	S70214013
16	ventola	M60100008
17	copriventola	M60200028
18	morsettiera trifase	M61100003
18	morsettiera monofase	M61100008
19	coprimorsettiera	M62700006
20	paraspruzzi	M72606003
21	dado bloccaggio girante	M60513006
22	cuscinetto lato pompa	M60300021
23	cuscinetto lato ventola	M60300003
24	anello di compensazione	M60603009
25	tirante motore	M75450011
26	condensatore 75 μ F - 450 V	M61400020
28	tappo di riempimento	M75147000
29	tappo di scarico	M75147000
31	anello O-R corpo pompa	M60900061
38a	rondella distanziale tenuta meccanica	M60600015
39	distanziale intermedio girante	M75118025
39a	distanziale giranti per diffusore con boccola	M75118030
47	tirante pompa	M75450053
49	tubo acciaio	M71401053
50	flangia bocca aspirazione	S70013009A
51	anello O-R bocca aspirazione	M60900044
52	flangia bocca mandata	S70013009A
53	anello O-R bocca mandata	M60900044
54	vite flangia	M60500148

62	scatola portacondensatore	M62700016P
76	bussola per diffusore	M75150013
93	semianello d'arresto	M60602011
94	rondella spallamento giranti	M60601011