

NEW

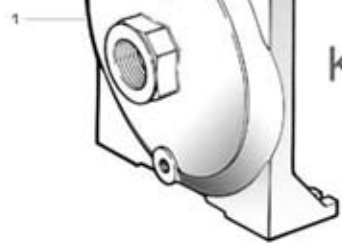

KM400-550

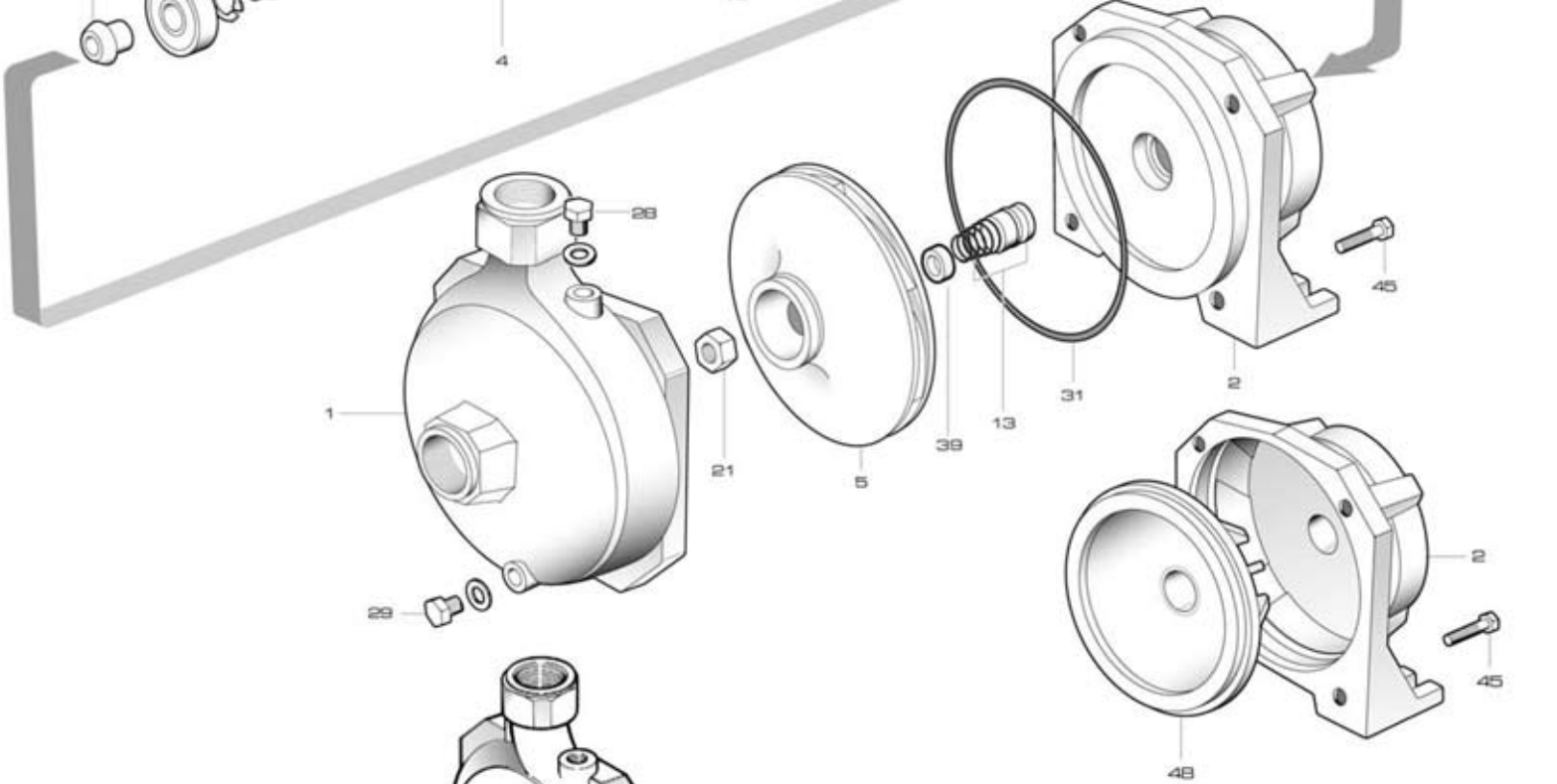
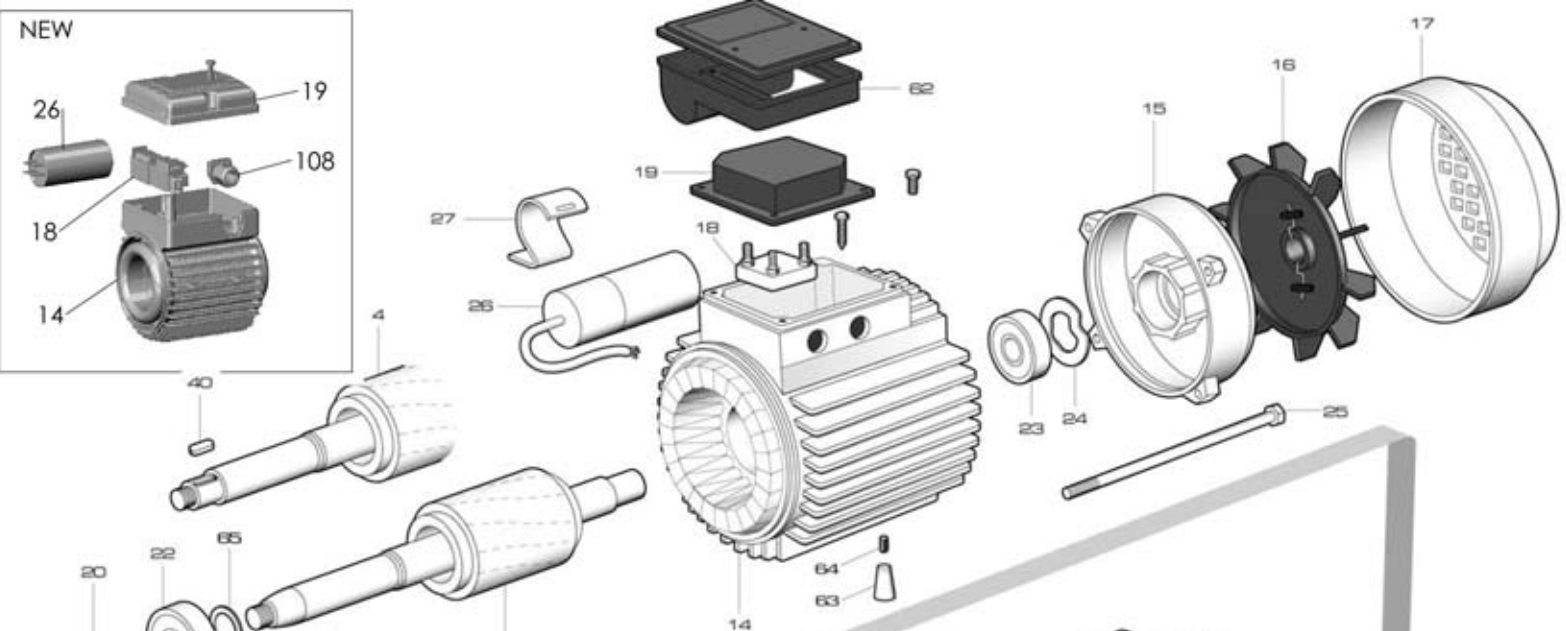
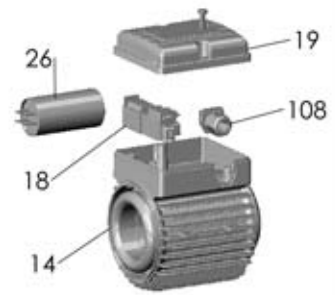
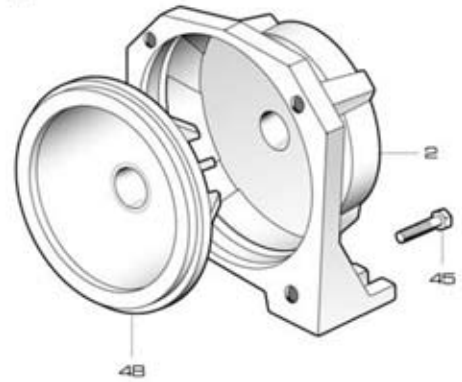

KM 75-100
supporto alluminio
aluminium motor bracket

KM 400

RIF	DESCRIZIONE	CODICE
1	corpo pompa	S70017061
2	supporto pompa motore ghisa	S70046028
4	albero con rotore monofase	S75405018S
4	albero con rotore trifase	S75405018B
5	girante ottone	S71127009B
13	tenuta meccanica	M60400012/3
14	cassa con statore monofase	S57900295
14	cassa con statore trifase	S57900249
15	coperchio motore	S70214007
16	ventola	M60100004
17	copriventola	S71415003
18	morsettiera trifase	M61100004
18	morsettiera monofase	M61100008
19	coprimorsettiera trifase	M62700006
20	paraspruzzi	M72606000
21	dado bloccaggio girante	M60513011
22	cuscinetto lato pompa	M60300008
23	cuscinetto lato ventola	M60300004
24	anello di compensazione	M60603003
25	tirante motore	M75450004
26	condensatore 75 μ F - 450 V	M61400020
28	tappo di riempimento	M75147000
29	tappo di scarico	M75147000
31	anello O-R corpo pompa	M60900012
40	linguetta	M61000002
45	vite corpo-supporto ghisa	M60500069
62	scatola portacondensatore	M62700034A
63	pedino d'appoggio	M75403022
64	vite pedino	M60505028