

NEW

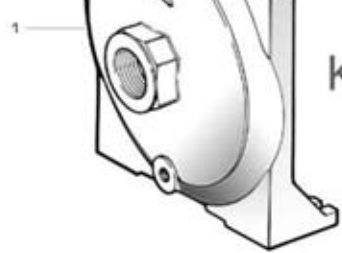

KM400-550

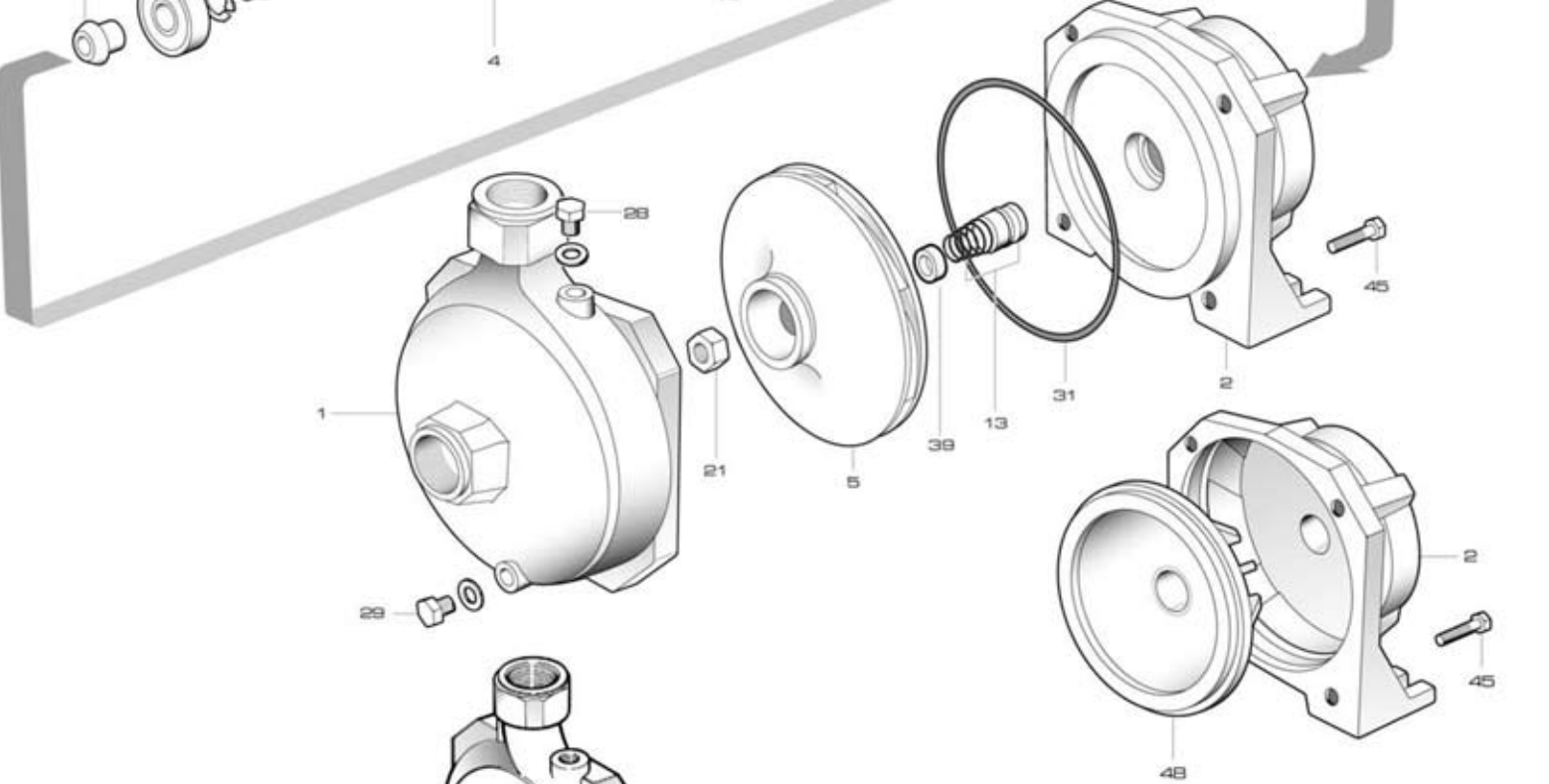
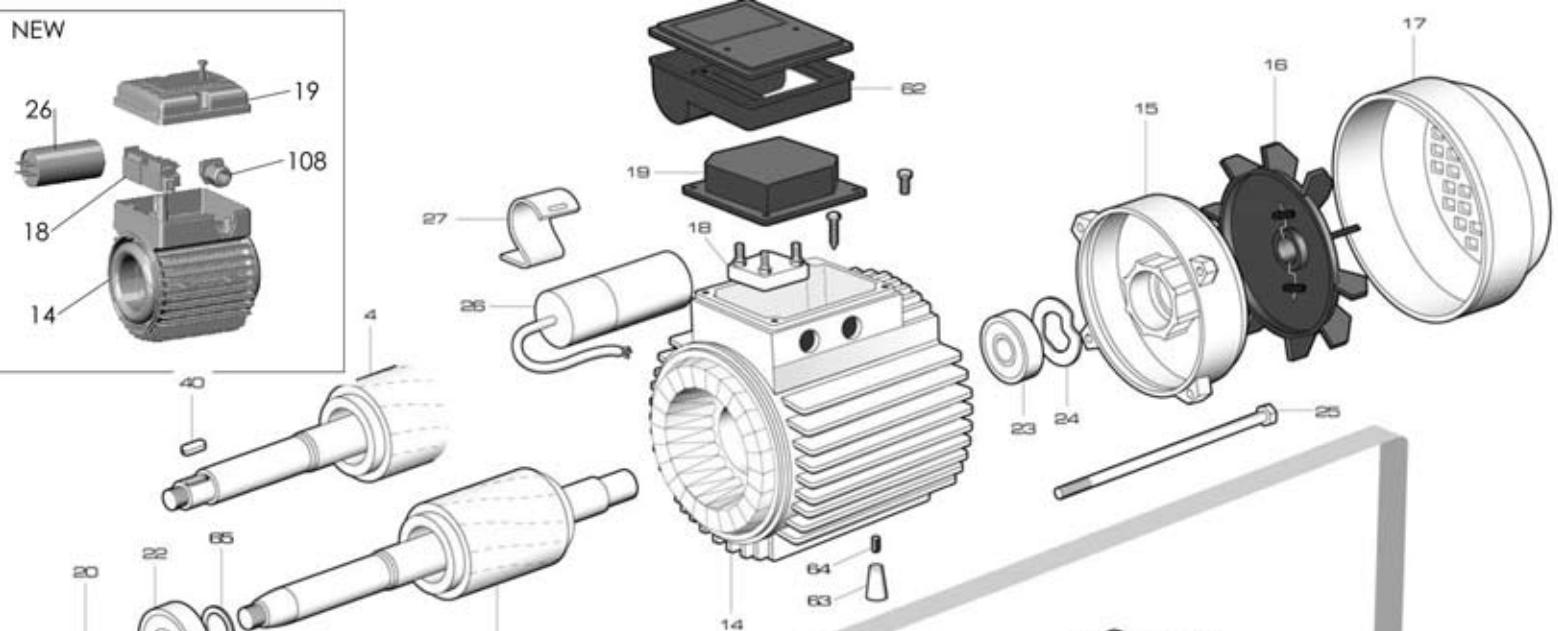
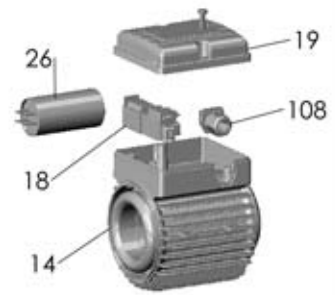
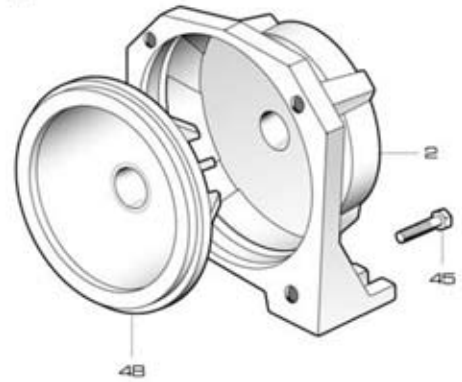

KM 75-100
supporto alluminio
aluminium motor bracket

KM 150

RIF	DESCRIZIONE	CODICE
1	corpo pompa	S70017012
2	supporto pompa motore ghisa	S70046003
4	albero con rotore monofase	S75405010
4	albero con rotore trifase	S75405010B
5	girante ottone	S71127008B
13	tenuta meccanica	M60400010/11
14	cassa con statore monofase	S57900014
14	cassa con statore trifase	S57900013
15	coperchio motore	S70214004
16	ventola	M60100003
17	copriventola	M60200027
18	morsettiera trifase	M61100003
18	morsettiera monofase	M61100008
19	coprimorsettiera	M62700001
20	paraspruzzi	M72606000
21	dado bloccaggio girante ottone	M60513004
22	cuscinetto lato pompa	M60300002
23	cuscinetto lato ventola	M60300002
24	anello di compensazione	M60603002
25	tirante motore	M75450003
26	condensatore 31,5 μ F - 450 V	M61400007
28	tappo di riempimento	M75147001
29	tappo di scarico	M75147001
31	anello O-R corpo pompa	M60900011
40	linguetta	M61000001
45	vite corpo-supporto ghisa	M60500069
62	scatola portacondensatore	M62700027
63	pedino	M72503013
64	vite pedino	M60505027
65	anello darresto	M60602001