

DESPIECE GENERADOR

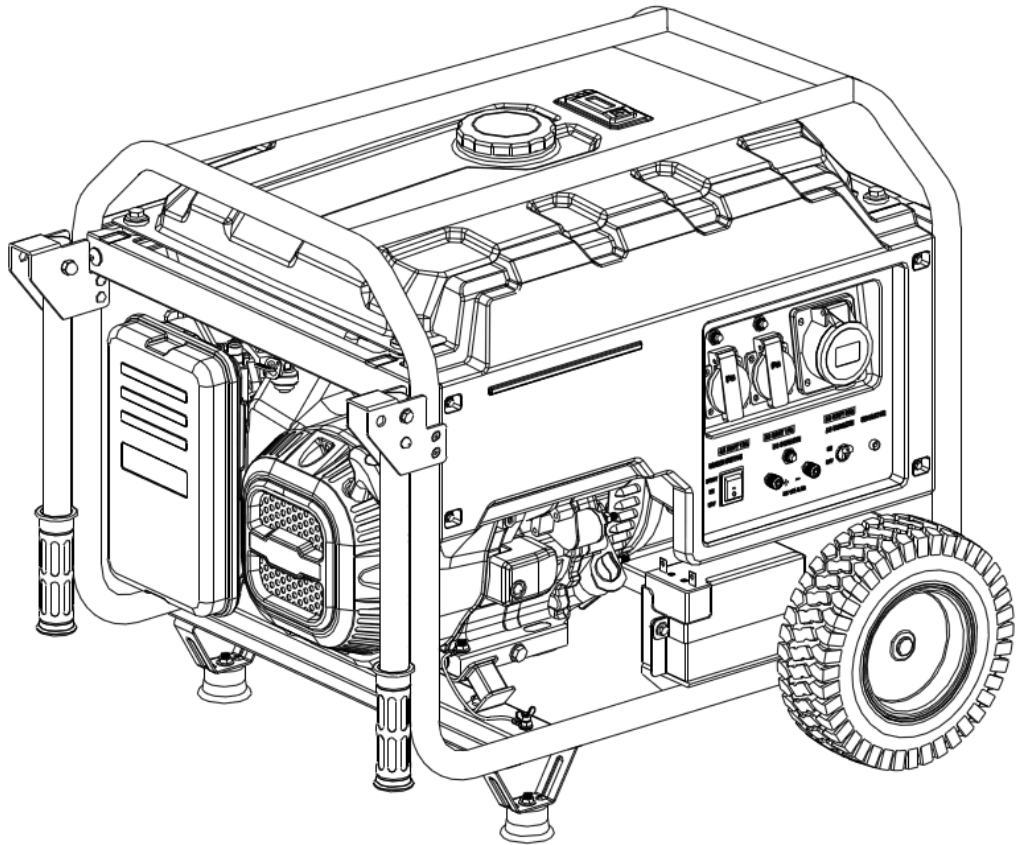

GENERADOR

8000A-3

Campeón

T/F Tecnoplus

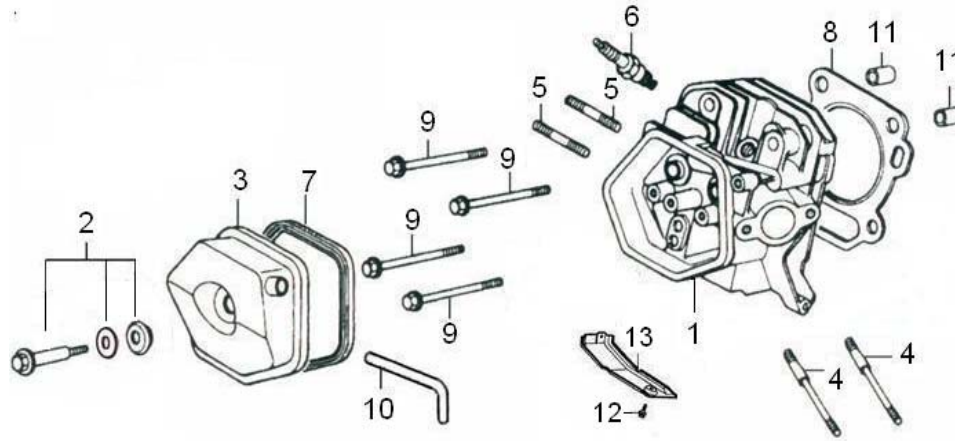

气缸头 (CYLINDER HEAD)

序号	零部件编号	零部件名称 (Description)		数量	单位	易损属性
Ser. No	Part No.			Reqd. QTY	UNIT	CONSUMABLE GRADE
1	120080338-0001	气缸头	CYLINDER HEAD COMP	1	件/PIECES	B
2	120420011-0001	气缸头盖螺栓组合	BOLT, COVER COMP. HEAD	1	套/SETS	C
3	120220009-0001	气缸头盖组合	COVER COMP. HEAD	1	件/PIECES	C
4	380180096-0001	双头螺栓, M6/8_L=106	BOLT, STUD, INTAKE	2	件/PIECES	C
5	380180098-0001	双头螺栓M8X34	BOLT, STUD, EXHAUST	2	件/PIECES	C
6	270960014-0001	火花塞	SPARK PLUG	1	件/PIECES	A
7	380840425-0001	密封圈	SEAL RING	1	件/PIECES	A
8	120150141-0001	气缸头密封垫	GASKET, CYLINDER	1	件/PIECES	A
9	380140337-0001	六角头法兰面螺栓M10X80	BOLT, FLANGE	4	件/PIECES	C
10	380740461-0001	通气管	TUBE, BREATHER	1	件/PIECES	A
11	380600116-0001	定位销	PIN	2	件/PIECES	C
12	380140001-0006	六角头法兰面螺栓M6×12	BOLT, FLANGE M6×12	1	件/PIECES	C
13	160190006-0001	空气导流罩	SHROUD	1	件/PIECES	C

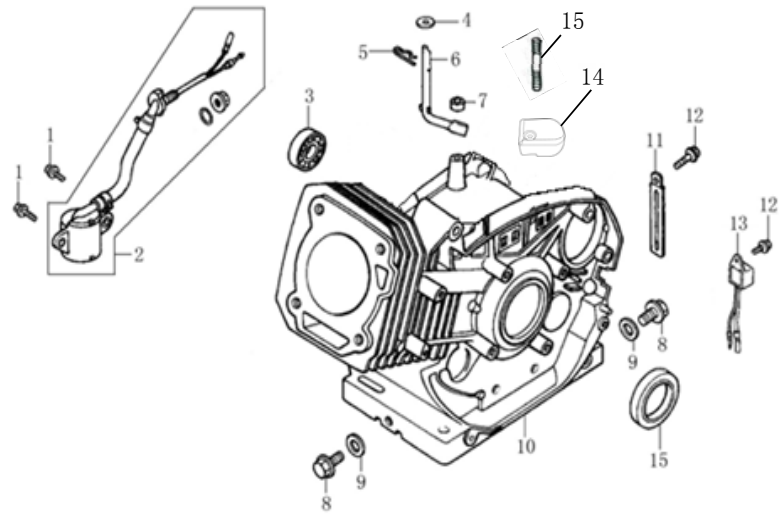

曲轴箱体 (CRANKCASE)

序号	零部件编号	零部件名称 (Description)		数量	单位	易损属性
Ser. No	Part No.			Reqd. QTY	UNIT	CONSUMABLE GRADE
1	380140215-0003	螺栓 M6×14	BOLT, FLANGE, 6×14	2	件/PIECES	C
2	281850152-0001	油位传感器	SWITCH ASSY., OIL LEVEL	1	件/PIECES	B
3	380630099-0001	轴承6202	BEARING, RADIAL BALL, 6202	1	件/PIECES	B
4	380450522-0001	平垫圈 8_16X1.2	WASHER, 8*16*1.2	1	件/PIECES	C
5	381350004-0001	销夹	PIN, LOCK, 10MM	1	件/PIECES	A
6	171630003-0001	调速臂	SHAFT, GOVERNOR ARM	1	件/PIECES	B
7	380650339-0001	油封	OIL SEAL, φ8×φ14×4	1	件/PIECES	B
8	110260024-0001	密封螺塞	BOLT, DRAIN PLUG	2	件/PIECES	C
9	380450516-0001	平垫圈	WASHER	2	件/PIECES	C
10	110810220-0001	曲轴箱体	CRANKCASE	1	件/PIECES	B
11	380940346-0001	线夹	CABLE CLEAT	1	件/PIECES	B
12	380140001-0006	螺栓 M6X12	BOLT, FLANGE, 6×12	2	件/PIECES	C
13	281890001-0001	机油保护器	ALERT UNIT, OIL	1	件/PIECES	A
14	284070007-0001	传感器外罩		1	件/PIECES	B
15	380180166-0001	双头螺栓	BOLT, STUD, INTAKE	1	件/PIECES	C

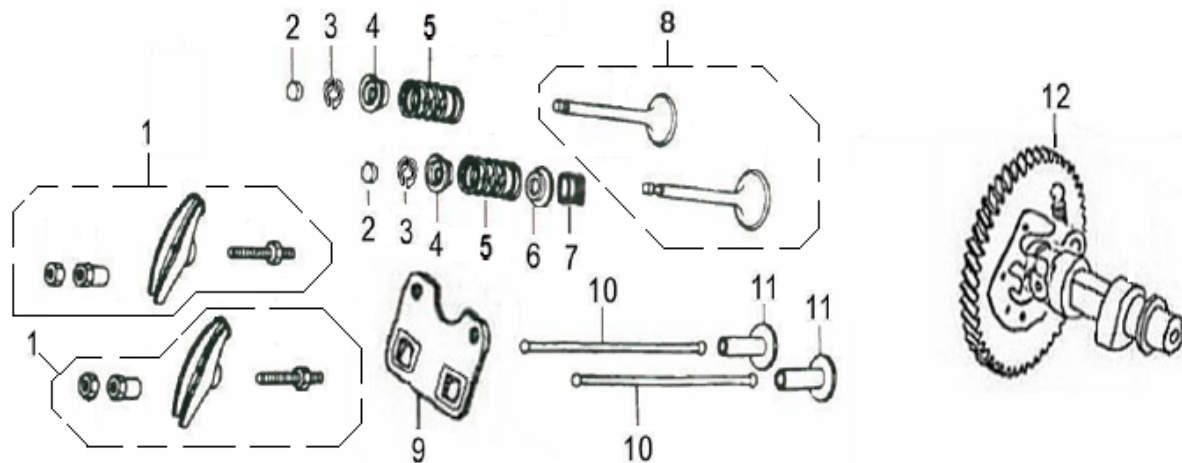

配气系统 (ROCKER, CAMSHAFT)

序号	零部件编号	零部件名称 (Description)		数量	单位	易损属性
Ser. No	Part No.			Reqd. QTY	UNIT	CONSUMABLE GRADE
1	140450023-0001	气门摇臂组合	ROCKER ARM ASSY.	2	套/SETS	B
2	140320002-0001	气门调整帽	ROTATOR, VALVE	2	件/PIECES	B
3	140390015-0001	气门锁夹	VALVE LOCKER	4	件/PIECES	B
4	140380021-0001	气门弹簧座	RETAINER, EX. VALVE SPRING	2	件/PIECES	B
5	140340025-0001	气门内弹簧	SPRING, VALVE	2	件/PIECES	B
6	140360010-0001	气门内弹簧座圈	SEAT, VALVE SPRING	1	件/PIECES	B
7	140400012-0001	挡油罩	SEAL, VALVE STEM	1	件/PIECES	B
8	500550032-0001	气门套件	VALVE ASSY.	1	套/SETS	B
9	140710002-0001	推杆限位板组合	PLATE ASSY.	1	件/PIECES	B
10	140670006-0001	挺杆组合	PUSH ROD	2	件/PIECES	B
11	140690004-0001	挺柱	LIFTER, VALVE	2	件/PIECES	B
12	140020056-0001	凸轮轴组合	CAMSHAFT ASSY.	1	件/PIECES	B

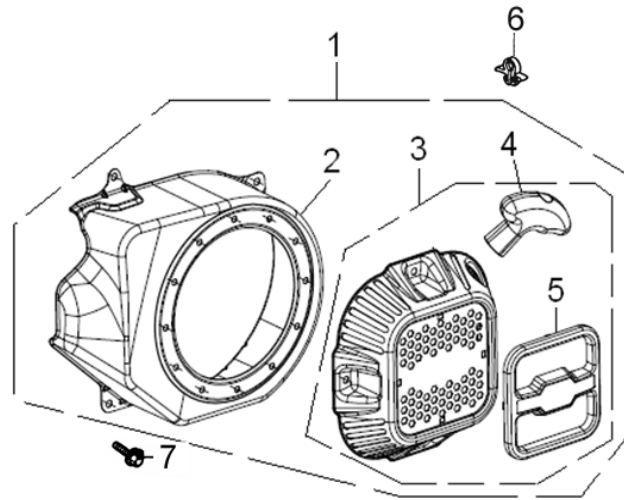

启动器 (STARTER)

序号	零部件编号	零部件名称 (Description)		数量	单位	易损属性
Ser. No	Part No.			Reqd. QTY	UNIT	CONSUMABLE GRADE
1	193490247-0001	手起动组件	RECOIL STARTER COMP. (ROJO)	1	套/SETS	B
1	193490247-0010	手起动组件	RECOIL STARTER COMP. (AZUL)	1	套/SETS	B
2	160210091-T61F	风扇罩部件	COVER COMP ., FAN (ROJO)	1	件/PIECES	C
2	160210091-T61FB	风扇罩部件	COVER COMP ., FAN (AZUL)	1	件/PIECES	C
3	193500106-T61F	手起动部件	STARTER ASSY. (ROJO)	1	套/SETS	B
3	193500106-T61FB	手起动部件	STARTER ASSY. (AZUL)	1	套/SETS	B
4	193560004-0002	拉绳手柄	KNOB, RECIOL STARTER (Yellow)	1	件/PIECES	B
5	193690018-T61F	启动器装饰罩	DECORATE COVER, RECOIL	1	件/PIECES	B
6	380930027-0001	定位线卡	CLIP, WIRE HARNESS	1	件/PIECES	A
7	380140001-0006	六角头法兰面螺栓M6X12	BOLT, FLANGE	5	件/PIECES	C

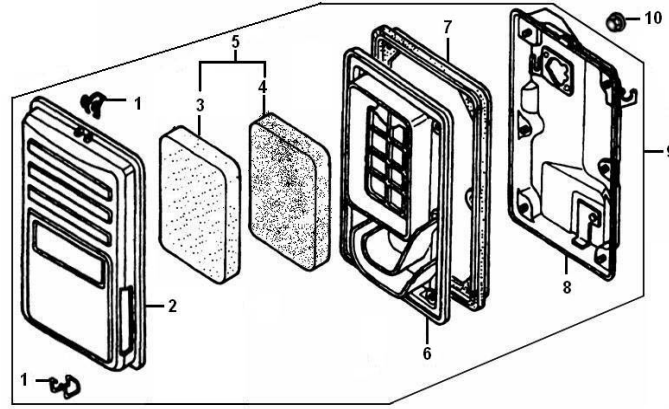

空滤器 (Air cleaner)

序号 No.	零部件件号 Part No.	零部件名称	Description	数量 Reqd. QTY	单位 UNIT	易损属性 CONSUMABLE GRADE
1	180170011-0001	空滤器盖板卡子	CLIP A, AIR CLEANER WIRE	2	件/PIECES	B
2	180070088-0001	空滤器壳体盖	COVER, AIR CLEANER	1	件/PIECES	B
3	180130121-0001	空滤器滤芯	ELEMENT, AIR CLEANER	1	件/PIECES	A
4	180130118-0001	空滤器滤芯	ELEMENT, AIR CLEANER	1	件/PIECES	A
5	180100036-0001	空滤器滤芯组合	ELEMENT, AIR CLEANER ASSY.	1	件/PIECES	A
6	180330021-0001	滤芯支撑板体	SEPARATOR, AIR CLEANER	1	件/PIECES	B
7	380840434-0001	密封圈	SEAL, AIR CLEANER	1	件/PIECES	A
8	180280006-0001	空滤器座	CASE COMP., AIR CLEANER	1	件/PIECES	B
9	180020318-0001	空滤器	AIR CLEANER	1	套/SETS	B
10	380370048-0001	六角法兰面螺母	NUT, FLANGE	2	件/PIECES	C

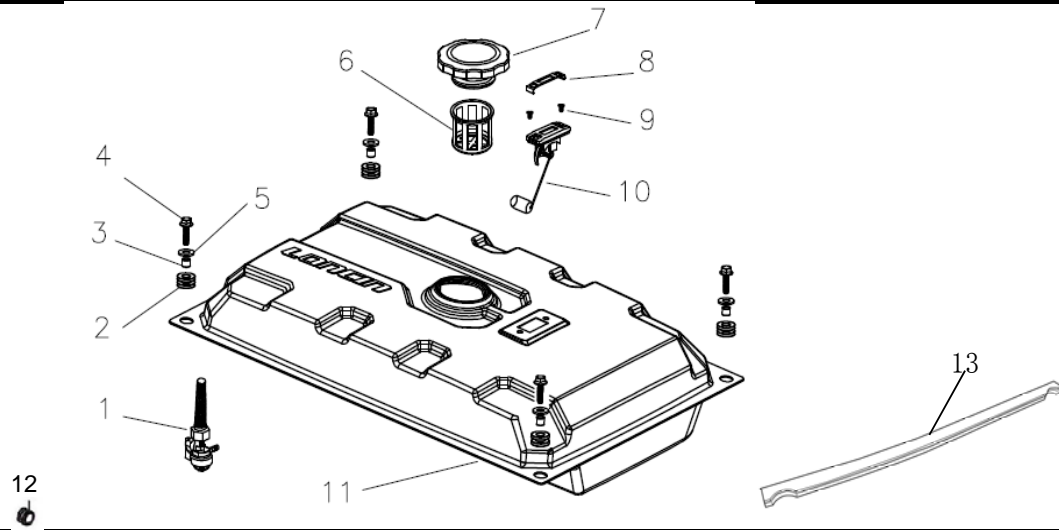

油箱 (FUEL TANK)

序号	零部件编号	零部件名称 (Description)		数量	单位	易损属性
Ser. No	Part No.			Reqd. QTY	UNIT	CONSUMABLE GRADE
1	170980057-0001	油开关部件	FUEL VALVE	1	件/PIECES	B
2	170700050-0001	油箱减震胶垫	RUBBER, FUEL CUSHION	4	件/PIECES	A
3	170710014-0001	油箱减震垫衬管	COLLAR, TANK CUSHION	4	件/PIECES	C
4	380140103-0004	六角法兰面螺栓M6×25	BOLT, FLANGE, M6×25	4	件/PIECES	C
5	380450444-0002	平垫圈	WASHER, FLAT	4	件/PIECES	C
6	170720014-0001	注油口滤网组合	FILTER, FUEL TANK	1	件/PIECES	A
7	170870044-0009	油箱盖	CAP COMP., FUEL FILLER	1	件/PIECES	B
8	281870016-0001	油传感器卡子	LABEL, FUEL METER	1	件/PIECES	B
9	380220044-0002	十字槽沉头螺钉M5×12	SCREW, FLAT, M5×12	2	件/PIECES	C
10	170740017-0001	油标部件	FUEL METER	1	件/PIECES	B
11	170501013-0003	油箱	FUEL TANK (ROJO)	1	件/PIECES	B
11	170501013-0003B	油箱	FUEL TANK (AZUL)	1	件/PIECES	B
12	380770188-0001	保护套管	PROTECTIVE SLEEVE	1	件/PIECES	A
13	172820008-0001	油箱胶条	RUBBER STRIP, FUEL TANK	1	件/PIECES	A

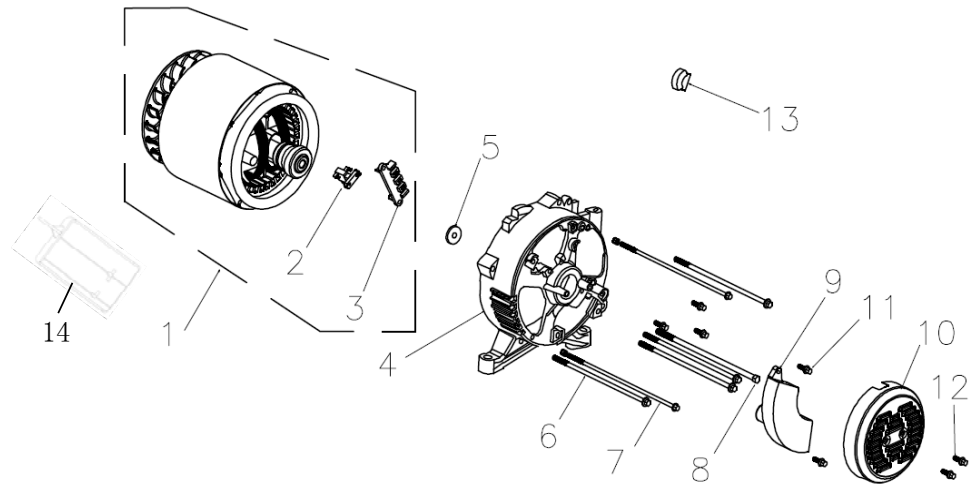

电机部件 (ALTERNATOR)

序号	零部件编号	零部件名称 (Description)		数量	单位	易损属性
Ser. No	Part No.			Reqd. QTY	UNIT	CONSUMABLE GRADE
1	660080427-0001	电机部件	ALTERNATOR	1	套/SETS	B
2	660140001-0001	电压接线板	TERMINAL, VOLT CHANGE	1	件/PIECES	C
3	660120001-0001	碳刷组合	BRUSH	1	件/PIECES	A
4	660010002-0001	电机后支撑	HOUSING, RR	1	件/PIECES	C
5	380450515-0001	平垫圈	WASHER, FLAT	1	件/PIECES	C
6	380140349-0001	六角头法兰面螺栓M6*185	BOLT, FLANGE	4	件/PIECES	C
7	380140496-0001	六角头法兰面螺栓M5*220	BOLT, FLANGE,	2	件/PIECES	C
8	380070185-0001	六角头螺栓M10*275	BOLT	1	件/PIECES	C
9	660150139-0001	调压器	AVR	1	件/PIECES	A
10	660020002-0022	电机后端盖	COVER, GENERATOR END (ROJO)	1	件/PIECES	C
10	660020002-0005	电机后端盖	COVER, GENERATOR END (AZUL)	1	件/PIECES	C
11	380140053-0002	六角头法兰面螺栓M5*16	BOLT, FLANGE	3	件/PIECES	C
12	380140167-0002	六角头法兰面螺栓M5*12	BOLT, FLANGE	6	件/PIECES	C
13	660030002-0001	电机挡块	COVER, GENERATOR	1	件/PIECES	C
14	660070001-0001	电机盖板		1	件/PIECES	C

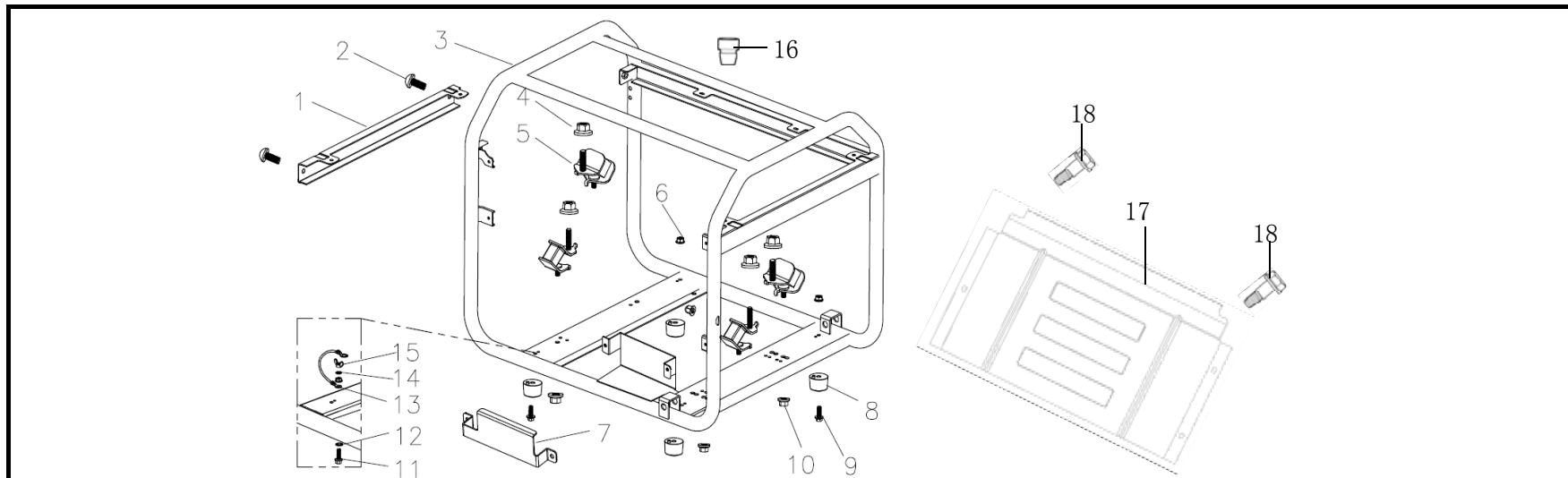

机架 (FRAME)

序号	零部件编号	零部件名称 (Description)		数量	单位	易损属性
Ser. No	Part No.)			Reqd. QTY	UNIT	CONSUMABLE GRADE
1	300730024-0003	机架横档	FRAME RAIL	1	件/PIECES	C
2	380190191-0001	内六角螺钉M8*16	SOKET HEAD CAP SCREW	2	件/PIECES	C
3	300720399-0001	机架部件	FRAME	1	件/PIECES	C
4	380370077-0001	六角法兰面螺母M10	NUT, FLANGE, M10	4	件/PIECES	C
5	300770023-0001	机架减震座	RUBBER , BOTTOM	1	套/SETS	B
6	380370048-0001	六角法兰面螺母M6	NUT, FLANGE, M6	4	件/PIECES	C
7	271170023-0003	蓄电池压架	PLATE, BATTERY SETTING	1	件/PIECES	C
8	300770005-0001	机架减震座	RUBBER , BOTTOM	4	件/PIECES	A
9	380140215-0003	六角法兰面螺栓M6*14	BOLT, FLANGE, M6*14	3	件/PIECES	C
10	380370007-0004	六角法兰面螺母M8	NUT, FLANGE, M8	4	件/PIECES	C
11	380140102-0004	六角法兰面螺栓M6*20	BOLT, FLANGE, M6*20	1	件/PIECES	C
12	380490022-0002	锁紧垫圈	WASHING, LOCK	1	件/PIECES	C
13	272980009-0001	通机接地线	GROUND LINE	1	件/PIECES	A
14	380450531-0001	平垫圈	WASHING	1	件/PIECES	C
15	380440003-0001	蝶形螺母	NUT	1	件/PIECES	C
16	170700051-0001	油箱减震胶垫	RUBBER TANK CUSHION	2	件/PIECES	A
17	303070041-0001	机架护板	FRAME SHEET GUARD	1	件/PIECES	C
18	303480002-0001	机架护板螺栓		2	件/PIECES	C
--	TW00630024		RUEDA	2	件/PIECES	B

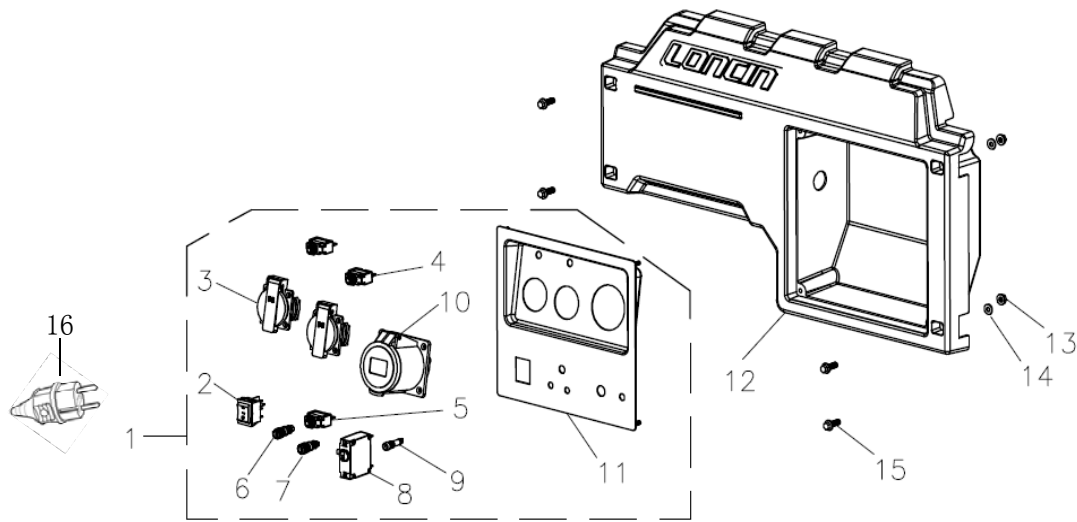

控制面部件 (CONTROL PANEL ASSY.)

序号	零部件编号	零部件名称 (Description)		数量	单位	易损属性
Ser. No	Part No.			Reqd. QTY	UNIT	CONSUMABLE GRADE
1	271852102-0001	控制面板部件	COTROL PANEL ASSY.	1	套/SETS	B
2	271810002-0001	启动控制开关	ENGINE SWITCH	1	件/PIECES	A
3	271890001-0001	插座 (欧式16A)	SOCKET	2	件/PIECES	B
4	271290055-0001	过流保护器16A	CIRCUIT BRERKER	2	件/PIECES	A
5	271290024-0001	过流保护器10A	CIRCUIT BRERKER	1	件/PIECES	A
6	272080001-0001	正极接线柱组合	POST , ARODE	1	件/PIECES	C
7	272090001-0001	负极接线柱组合	POST , CATHODE	1	件/PIECES	C
8	BREAKER-8000A3	过流 (断路) 保护器27A	CIRCUIT BRERKER	1	件/PIECES	A
9	283730004-0001	电压指示灯	LAMP	1	件/PIECES	A
10	271890009-0001	插座 (欧式工业)	SOCKET	1	件/PIECES	B
11	271860138-T57F	控制面板	PANEL	1	件/PIECES	C
12	271970014-0001	面板座	PANEL BACK COVER	1	件/PIECES	B
13	380370047-0003	六角法兰面螺母M4	NUT	4	件/PIECES	C
14	380450526-0001	平垫圈	WASHER	4	件/PIECES	C
15	380140215-0003	六角法兰面螺栓M6*14	NUT	4	件/PIECES	C
16	271880005-0001	电源插头组合	PLUG	2	件/PIECES	B
--	272890003-0002		CUENTA HORAS	1	件/PIECES	B