

2XCM 25/160A

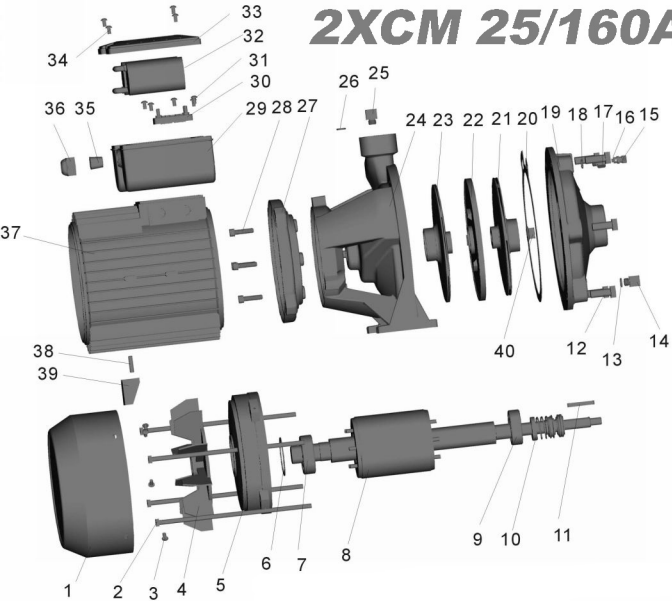

2XCM 25/160A

N.FIGURA	REFERENCIA	DENOMINACION
1	2XCM25160A-1	TAPA VENTILADOR
2	2XCM25160A-2	TORNILLO
3	2XCM25160A-3	TORNILLO
4	2XCM25160A-4	VENTILADOR
5	2XCM25160A-5	SOPORTE TRASERO MOTOR
6	2XCM25160A-6	ARANDELA MUELLE
7	2XCM25160A-7	ROZAMIENTO
8	2XCM25160A-8	EJE-ROTOR
9	2XCM25160A-9	RODAMIENTO 6205-2RS
10	2XCM25140M-11	SELLO MECANICO
11	2XCM25160A-11	CHAVETA
12	2XCM25160A-12	TORNILLO
13	XCM158-20	JUNTA TORICA
14	XCM158-19	TAPON DE DESAGÜE
15	2XCM25140M-19	PURGADOR
16	2XCM25160B-8	JUNTA TORICA
17	2XCM25140M-21	CUERPO PURGADOR
18	2XCM25160A-18	JUNTA TORICA
19	2XCM25160A-19	CUERPO BOMBA
20	2XCM25160A-20	JUNTA
21	2XCM25160A-21	RODETE
22	2XCM25160A-22	PLATO INTERMEDIO
23	2XCM25160A-23	RODETE
24	2XCM25160A-24	SOPORTE BOMBA
25	2XCM25160A-25	TAPON DE LLENADO
26	XJWM/3BH-26	JUNTA
27	2XCM25160A-27	PLATO INTERMEDIO
28	2XCM25160A-28	TORNILLO
29	2XCM25160A-29	CAJA CONEXIONES
30	2XCM25160A-30	REGLETA
31	2XCM25160A-31	TORNILLO
32	2XCM25160A-32	CONDENSADOR 32,5 MF
33	2XCM25160A-33	TAPA CAJA CONEXIONES
34	2XCM25160A-34	TORNILLO
35	2XCM25160A-35	PARTE INTERNA PASA CABLES
36	2XCM25160A-36	PARTE EXTERNA PASA CABLES
37	2XCM25160A-37	ESTATOR
38	2XCM25160A-38	PIN
39	2XCM25160A-39	APOYO
40	2XCM25160A-40	TUERCA